

智元 D1 Max

产 品 说 明 书



1.版本申明

- 01 法律声明
- 02 注意事项

2.产品介绍

- 01 产品概述
- 02 部件名称
- 03 核心规格
- 04 灯效说明
- 05 扩展接口
- 06 运动模式

3.机器狗使用说明

- 01 环境要求
- 02 开箱
- 03 启动前检查
- 04 启动前准备
- 05 启动及操作
- 06 换电与关机
- 07 急停与保护
- 08 载荷扩展
- 09 设备充电
- 10 搬运
- 11 存储

4.遥控器使用说明

- 01 遥控操控说明
- 02 APP使用说明

5.异常与解决

6.日常维保

7.保修政策

法律声明

在使用本产品前，请用户务必仔细阅读本产品说明书，并严格按照本手册内容操作本产品。任何违反本手册内容使用而导致的财产损失或人身伤害，本公司概不负责。本产品由多个零部件构成，请确保儿童无法接触本产品，以避免意外发生。本产品仅限 18 周岁以上人士使用。为延长产品使用寿命，请勿在高温、高压环境中使用。本手册尽可能包含本产品的功能介绍和使用说明，但由于功能不断完善和设计变更等原因，实物与手册内容可能存在偏差。如实物与本手册在颜色、外观等方面有出入，请以实物为准。

本说明书适用于D1 Max版本（产品型号：ZYCXD125M）。

A. 机器狗应用

- 地形地貌：请尽量避免在玻璃、冰面等光滑路面行走，如必须行走，请尽量降低机器狗行走速度，以避免打滑摔倒。
- 气候天气：请尽量避免在大雾、雷雨、沙暴、大风天等恶劣天气应用机器狗。
- 通信干扰：请勿在有 WIFI、射频等通信信号干扰严重的环境下操控机器狗，如必须，则务必关闭通信信号干扰源，或者降低信号源干扰。
- 电磁干扰：请勿在高压电线、高压电站、通信基站、信号塔等强电磁干扰环境下操控机器狗，如必须，请先咨询售后。
- IP 防护：机器狗的防护等级为 IP67, 可以水下 1 米潜行 30 分钟。在进行功能应用时，需要提前确保机器狗的状态，包括外观无破损、扩展接口盖盖好、电池和电池仓干燥无水等；在执行完 30 分钟潜行之后，需要将机器狗及时脱离水面，并将机身参审干净干燥处理和维护后，再进行下次潜行操作。因长时间浸水等原因造成机器狗故障，则不在保修范围内。
- 最大速度：机器狗最大速度可达 6m/s, 冲击力巨大，因此在高速状态下，请确保机器狗远离人群。
- 运动模式：机器狗分为原地模式、运动模式、巡航模式、登阶模式，在使用过程中，请根据环境场景，切换不同的运动模式。
- 摔倒恢复：机器狗摔倒后恢复站立姿态需要空间，为避免碰撞，请确保机器狗周围 2 米内没有人和物体，请勿在机器狗硬急停没有触发的情况下拖拽摔倒的机器狗。

B. 电池应用

- 在首次使用前，如果电池发出明显的异味、发热或锈蚀迹象，请联系电池供应商。
- 给儿童使用前成人必须讲解清楚如何使用设备和电池，并定期跟踪确认，以确保儿童正确使用。
- 请勿在极高温（例如超过 60°C，如强烈的阳光直射下或处于极热环境的车辆内）下使用或放置电池。否则，电池可能会过热、起火，其性能会退化，使用寿命会缩短。

- 请勿在静电超过 1000V 的环境中使用电池，因为这可能会损坏保护电路，并造成安全隐患。
- 电池只能在 0 ~ 50°C 的温度范围内充电。在此温度范围外充电可能会导致电池漏液、发热，或造成严重损坏。这也可能导致电池的性能和寿命退化。
- 请不要靠近易燃材料充放电电池，否则可能产生起火隐患。
- 电池在检测到单体欠压时自动进入仓储模式，该模式下电池不响应开关且电池指示灯常灭，电池充电后可退出仓储模式。
- 电池按键关机后处于休眠模式，通讯、按键、充电都可以唤醒电池。
- 如果电池电路端子弄脏，使用前应用干布抹净，否则可能会因接触不良而影响性能失效。
- 电池应当在室温下存放，应充电到 30% ~ 60% 的电量。为防止电池过放，建议每 3 个月按标准充电方式进行充电至 50%；如储存时间超过一年，建议每年按标准充电方式进行一次充、放电循环以激活电池。
- 如果电池长期未使用，它可能会因为电池本身自放电而处于过放电状态（低于过放保护电压或者电芯的过放电压），甚至电芯过放到 0V。这种电池如果继续使用是有风险的。为防止过放电的发生，应定期将电池充电，让电池电压维持在 30% ~ 60% 电量。
- 插头线承受拉力有限，拉力过大会造成电池损坏。将电池装入机器后，确保电池和插头线不会随意摇摆。
- 禁止在靠近火、加热器或高温 (>80°C) 环境中使用或搁置电池。
- 禁止使用未经授权的充电器，由此造成的电池损害，不在保修范围内。
- 禁止将电池极性反转连接，禁止使用导线等金属物体直接连接电池正负极短路电池。
- 禁止焚烧电池或对其进行加热，禁止撞击、抛掷、踩踏等对电池的过度机械冲击，禁止使用钉子或其他尖锐物体刺穿电池。
- 禁止拆解电池，一经拆解，保修无效！

C.其他注意事项

- 如果机器狗出现进水现象，第一时间关闭机器狗电源，拔出电池，进行干燥晾晒。
- 如果机器狗出现冒烟、起火现象，优先选用二氧化碳、干粉等品类的灭火器灭火，切忌用泡沫灭火器灭火。
- 机器狗出现狗腿摆动等运动失控时，优先触发软急停、硬急停，在确保工作人员安全的情况下，关机拔电池，然后再进行问题排查；对于疑难问题，可反馈给技术支持人员，进行问题排查、设备维修、设备更换等。
- 禁止私自拆卸机器狗，一经拆卸，保修无效！

产品概述

D1 Max 是一款轮足式四足机器人，具备自重轻、负载大、续航长、防护强、运动灵活稳定等特点；机器狗每条腿配备 3 个关节电机和 1 个轮毂电机，支持轮足 / 点足更换；配备激光雷达、光学相机、超声波雷达、IMU、补光灯、RTK 模块等传感器，内部搭载高算力主控平台，用于实现运动控制、自主导航定位、环境侦检等功能，提供丰富的供电和通信接口，支持多品类的任务载荷的扩展。

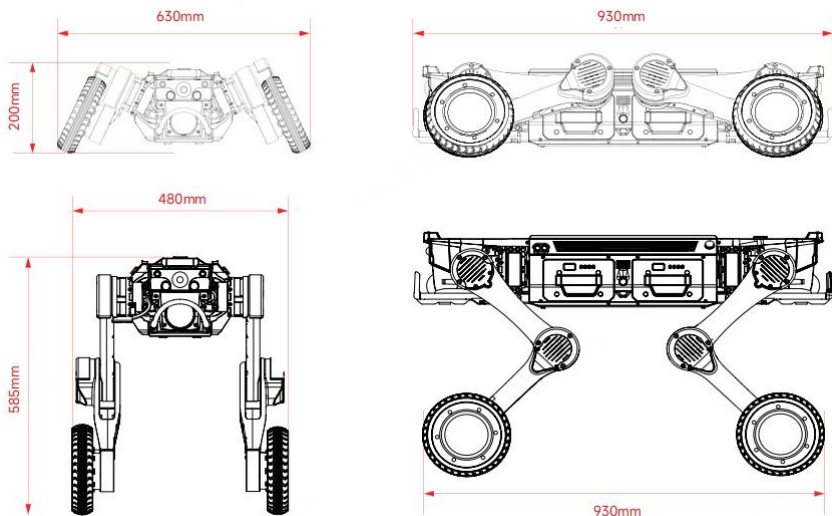

部件名称

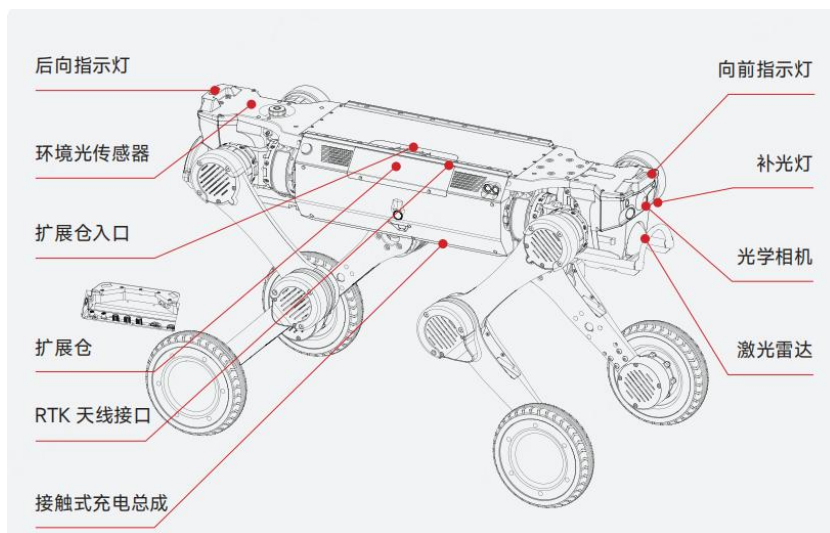
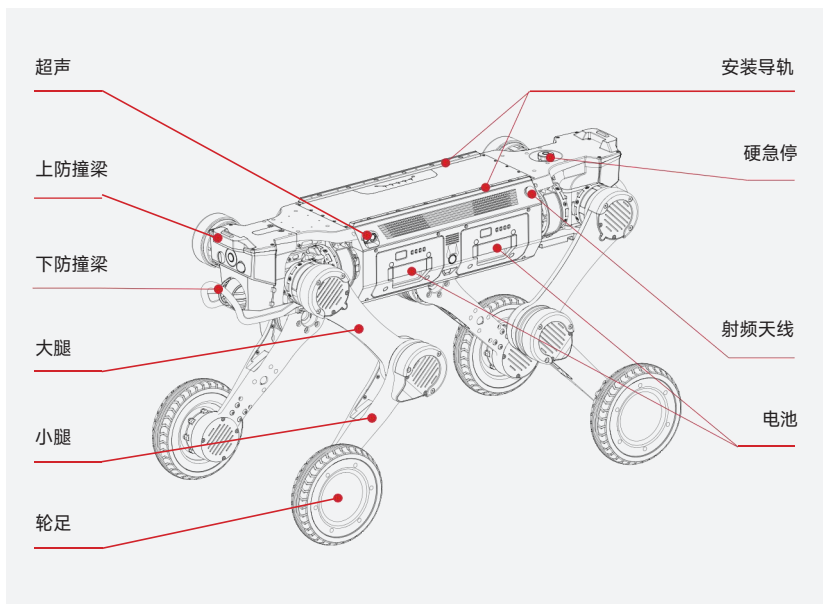

核心规格

分类	规格	说明
基本信息	产品型号	ZYCXD125M
	材质信息	铝合金 + 高强度工程塑料
	站立尺寸 (长 × 宽 × 高)	930mm*480mm*585mm
	趴地尺寸 (长 × 宽 × 高)	930mm*630mm*200mm
	整机重量 (含电池)	41kg
	电池重量	3.3kg/个
	轮足尺寸	8 寸
	防护等级	IP67
	工作温度	-20°C ~ 55°C
运动性能	自由度	12+4dof
	最大速度	8m/s
	额定负载	25kg
	最大爬坡角度	45°
	持续攀爬高度 (楼梯)	25cm
	最窄通过尺寸	50cm
	垂直越障高度	80cm
	水平越障距离	80cm
电池参数	电池容量	54V, 9.35Ah*2, 双电池支持快拆快换, 支持热插拔
	空载续航时间	5h
	满载续航时间	3.5h
	空载续航里程	29km
	满载续航里程	18km
	充电座输入电压	AC220V
	充电座输出电压 / 电流	DC63V, 最大充电电流 10A
	充电时长	单电池≤ 2h (充电座支持双电池同时充电)

注释说明:

- (1) 充电时长数据为在标准环境温度 25°C 下测得
- (2) 续航里程数据为在速度1m/s, 无负载工况下测得
- (3) 功能拓展接口使用说明, 详见拓展说明手册;
- (4) 详细的保修条款, 详见产品保修手册;
- (5) 以上参数为实验室测试数据, 实际表现可能因使用环境、操作方式等因素有所差异, 请以实际为准;

灯效说明

状态指示灯

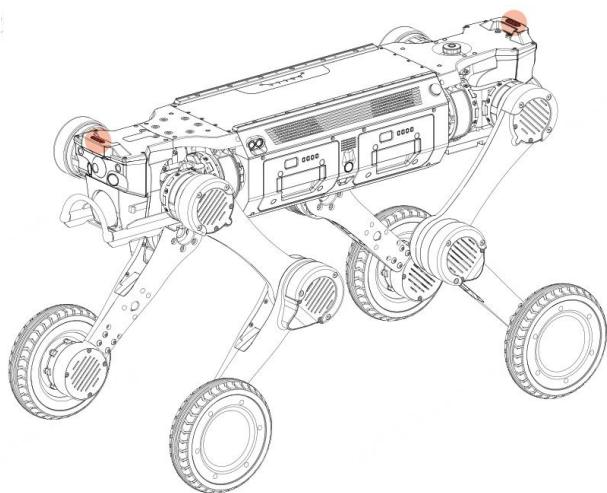

指示灯颜色	指示灯灯效	机器狗状态
白灯	慢闪	开机中
	常亮	手动控制 / 机器工作状态
	呼吸	待机
绿灯	慢闪	定位中 / 自动回程中
	常亮	自动任务执行中
黄灯	快闪	告警态
	常亮	低电
红灯	快闪	故障态
	常亮	软急停
蓝灯	常亮	升级中
/	呼吸态	充电中 (选配充电桩)



警示提示

- 硬急停：指示灯红灯常亮，硬急停按钮红灯常亮。
- 前后向切换：机器狗切换前后方向时，对应方向的状态灯会点亮，进而执行上述灯效。
- 除前后主方向状态切换时，前后灯有差异，其他情况下前后灯一致。

灯效说明

电池指示灯

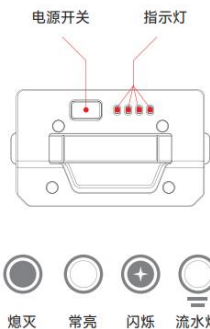
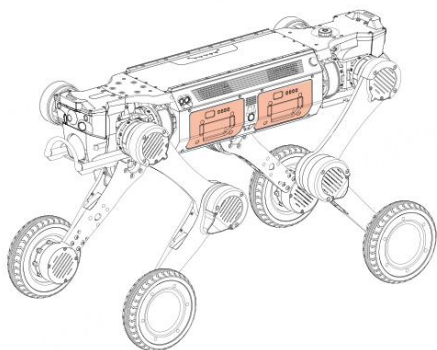

电池指示灯灯效	灯效说明	电量说明
○ ○ ○ ○	4 颗 LED 灯常亮	电量为 75%-100%
○ ○ ○ ●	前 3 颗 LED 灯常亮	电量为 50%-75%
○ ○ ● ●	前 2 颗 LED 灯常亮	电量为 25%-50%
○ ● ● ●	第 1 颗 LED 灯常亮	电量为 0%-25%
⊕ ● ● ●	第 1 颗 LED 灯闪烁	电量为 0%
▬ ○ ○ ○ ○	4 颗 LED 灯依次点亮	显示充电中, 满电后 4 颗 LED 灯常亮

急停指示灯

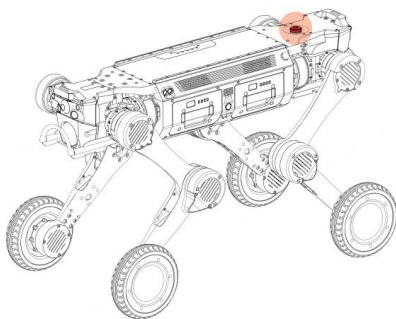

● 熄灭	硬急停未触发
○ 红灯常亮	硬急停被触发

扩展接口

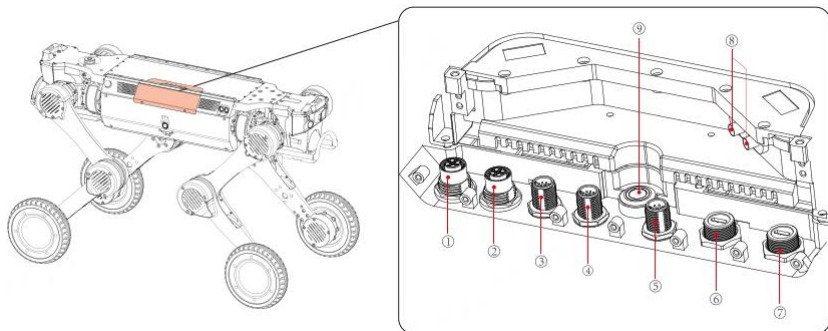

序号	接口名称
①	48V (10A) x1
②	24V (20A) x1
③	24V (3A) + 网口, 1 个
④	12V (5A) + 网口, 1 个
⑤	串口 (RS232 x1、RS485 x1、SBUS x2、PPS x1)
⑥、⑦	USB3.0 (5V、1A) , 2 个
⑧	RTK 天线接口
⑨	扩展仓按键



警示提示

- 在机器狗后背加装设备时，设备的重心、位置、接口、走线等规划设计，请务必在正式加装之前咨询售后人员；
- 所有供电接口的供电总功率在 480W 以内；
- 有航插头配备防护盖，以确保 IP67，不用的航插头务必盖好防护盖；
- 扩展仓按键用于控制扩展接口的供电，在进行上装接线时，务必先关闭扩展仓的电源。

运动模式

机器狗标配强化运控模型，具备原地模式、运动模式、导航模式、登阶模式：

原地模式	该模式下，机器狗保持原地不动，机器狗躯干执行旋转、俯仰、高低等各种动作。
运动模式	能够自动适应平地、斜坡、楼梯、各类复杂路面（山地、林地、瓦砾碎石）；能进行前进后退直线运动、进行原地旋转等运动；可以执行站立、匍匐、卧倒、锁定等动作；执行爬高台、扭一扭等特技。
巡航模式	该模式下可创建地图，地图生成完成后，即可基于该地图启用定点巡航功能，实现自动化巡检与定点作业。
登阶模式	该模式下，机器可自主规划步态，在多级楼梯间稳健跨越，适用于多层空间作业



警示提示

- 机器狗在执行爬高台特技时，确保电量在 2 格电以上，同时确保机器狗空载。请保持机器狗在视线范围内，同时与周围人群保持 2 米以上的安全距离；
- 机器狗在楼梯、斜坡等路面时，请确保没有人在机器狗的正上方、正下方、行进轨迹上；
- 运动模式下，机器狗标配分为低速、中速、高速档，为了保证机器狗安全执行任务，在中速、高速档，限制机器狗执行左右平移和原地旋转等动作。

环境要求

- 操作者在进行开机操作之前，充分阅读本手册，熟悉机器狗的各类功能状态、操作细节、注意事项等；
- 初次操作尽量避免机器狗超出视线范围，并保证机器狗周围 2 米以内没有工作人员和障碍物，以避免碰撞；
- 温度要求：请在 -20°C $\sim 55^{\circ}\text{C}$ 的环境温度下应用机器狗；
- 天气要求：请勿在大雾天、雷雨天、沙尘暴、龙卷风等恶劣天气下开机工作；
- 电磁环境要求：尽量避免在强电磁干扰（高压电线、高压输电站、通信信号塔等）环境下，以避免强磁击穿；
- 通信环境要求：请勿在通信信号干扰环境下开机并遥控操作，以避免机器狗通信干扰，造成失联。

开箱

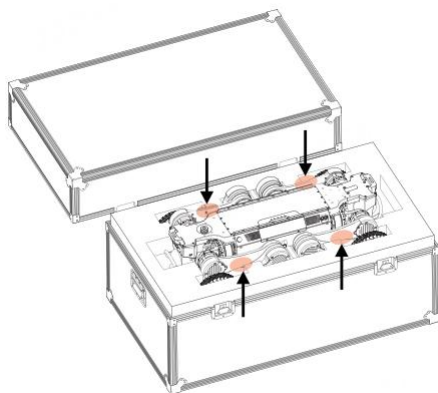

机器狗包装箱为航空箱，将包装箱放置在平整地面，方向向上，打开并移走包装箱上盖，将机器狗、电池、遥控器、充电座等依次搬出，放置在硬质平面上。



警示提示

- 搬出机器狗时，按照指示图抓住图示的搬运点，注意警示标签位置和内容，以避免在搬运过程中夹手、划伤；
- 搬运过程中对机器狗、电池、遥控器、充电座轻拿轻放；
- 搬运完成后，检查D1 Max 的急停按键、电池电源按键等未被触发。

启动前检查

A. 外观与机械结构检查

- 整体外观完整性：检查机身外壳是否存在裂痕、变形或脱落，重点关注关节连接处、传感器保护罩等易受损部位；观察机身表面是否有明显污渍、液体残留或异物附着，尤其是散热孔、接口处。
- 关节与运动部件检查：逐一检查机器狗的腿部关节、轮足，确认关节活动是否顺畅，无卡顿、异响或松动迹象。轮足 / 点足需确认防滑纹路是否清晰，无开裂、脱落；确认关节处的螺丝、卡扣等紧固件无缺失、松动。

B. 电池状态检查

- 电池外观：查看电池组外壳是否鼓包、漏液、破损，若出现鼓包可能是电池老化或过充，严禁使用，需立即更换，避免发生起火、爆炸风险。
- 电池连接：检查电池与机身的连接接口是否清洁，无氧化、锈蚀或异物，插合时需确保卡扣扣紧，避免接触不良导致供电中断。
- 电量检查：开机前可通过指示灯初步判断电量，至少有一个电池的电量在 2 格电以上，单击电池电源按键，即可显示电量；低电量状态下需先充电，避免开机后因电量不足导致中途停机，影响设备寿命。

C. 环境感知传感器检查

- 光学传感器：检查摄像头、激光雷达的镜头是否清洁，无污渍、划痕或遮挡物。
- 距离 / 避障传感器：检查超声波传感器等避障部件的探头是否完好，无遮挡。

D. 遥控器检查

- 检查遥控器的按键是否灵敏，无卡顿，电池电量是否充足（可通过遥控器指示灯判断），确保开机后能正常操控机器狗。
- 检查机身显示屏、指示灯、扬声器等反馈部件，确认显示屏无损坏、花屏，指示灯能正常亮起，便于开机后及时获取设备运行状态（如电量、故障提示）。

启动前准备

A. 安装电池

机器狗配备双电池仓，支持单电池供电、双电池供电两种模式，将电池对准电池仓的电池接口（有防插反设计），提拉电池的手带，将电池推入电池仓，到底后，松开手带，听到“咔嗒”声即卡扣锁紧。安装好后，检查电池安装状态，电池外包面应与机器狗机身处于平齐状态。

B. 机器狗摆放

采用水平趴卧姿势，即腹部完全贴紧地面，腿部采用自然分列机身两侧，小腿呈最小收拢姿态，4个膝关节与轮足平放在地面上，确保没有大腿小腿没有被躯干压住。

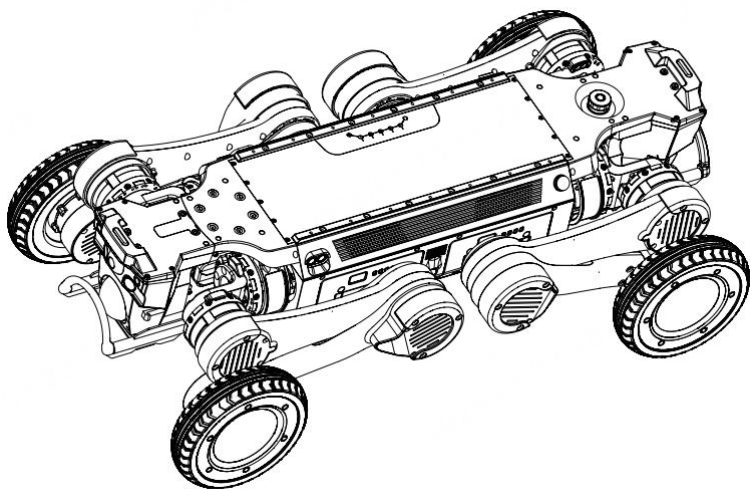

启动及操作

A. 机器狗开机流程

机器狗开机过程即为电池开机过程，具体操作为：短按电池按键，激活电池，电池指示灯常亮显示电池电量，然后长按电池 3 秒，电池开启，机器狗启动，状态指示灯白色频闪代表启动中，白色常亮代表启动完成，机器狗进入到通用运动模式。

机器狗支持单电池供电、双电池供电两种模式，具体开机分为如下：

机器狗电池状态	开机流程
机器狗处于关机状态，没有电池插入时	只插一块电池：直接插入开机后的电池，或者直接先插入关机的电池，然后为电池开机，机器狗启动；
机器狗处于关机状态，插入一块关机电池时	插入另一块开机电池，机器人启动；已经插入的关机电池，插入 1min 后，电池自动启动； 插入另一块关机电池，启动任意一个电池，机器狗开机；
机器狗处于关机状态，插入两块关机电池	任意电池开机，整机开机，另一块电池无需启动，自动接通。



警示提示

- 双电池具备互相唤醒功能，在双电池模式下，只具备双开、双关等两种状态，不支持电池一开一关的状态；
- D1 Max 单电池开机状态时，插入另一块开机 / 关机电池，该电池自动启动接通。

B. 遥控器开机

长按遥控器电源按键，遥控器屏幕点亮、遥控器电源指示灯点亮，由于出厂前遥控器与机器狗进行一对一匹配，因此遥控器启动后会自动与机器狗连接。

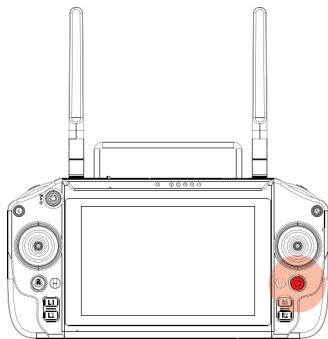

遥控器开启后，点击屏幕的 APP，进入 APP 控制界面，确认 APP 的健康状态后，即可进行机器狗操控。

C. 操作引导

遥控操作说明，参看本说明书“遥控器使用说明”。

D. 首次开机验证

- 基础运动测试：通过遥控器的 APP 控制机器狗完成简单动作，如站立、趴下、前后左右直线运动、转弯等，确认关节运动顺畅，若出现卡顿、异响或无法站立，需立即关机检查关节是否卡滞或姿态错误。
- 传感状态测试：视觉、激光、超声、惯导等各类传感器运行正常，数据能在 APP 上正常显示。
- 状态反馈检查：观察指示灯、显示屏或 APP 显示的设备状态，确认电量、连接信号、固件版本等信息正常，若有故障提示需按操作手册排查。

换电与关机

A. 换电池

机器狗具备双电池、热插拔功能，在双电池共同供电的情况下，可以直接拔下一个开机电池，换上一个开机 / 关机状态的电池，机器狗在换电池过程中保持正常工作，并实现双电池供电；

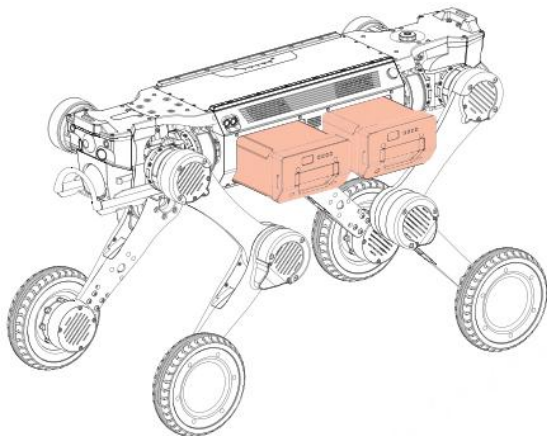

B. 关机

机器狗关机：在单电池、双电池供电模式下，关闭任意电池，电池灯灭，机器狗状态指示灯熄灭，机器狗关机；



警示提示

- 尽量先调整机器狗到水平趴卧姿态，再进行关机姿态；限制在机器狗站立姿态下，直接进行关机。
- 当机器狗只有一个开机电池时，禁止通过直接拔出开机状态电池来进行关机。

急停与保护

A. 硬急停触发与解除

- 硬急停触发：机器狗在自主运动状态、遥控状态下，出现失控、故障等问题时，操作者拍下机器狗背部的红色硬急停按键，硬急停红色灯常亮，触发硬急停保护，机器狗缓慢趴下，保持静止不动；APP 端同步弹窗示警。
- 硬急停解除：顺时针旋转硬急停按键，即解除硬急停。

B. 软急停触发与解除

- 软急停触发：机器狗在自主运动状态、遥控状态下，出现失控、故障等问题时，操作者可以触发遥控器软急停按键，机器狗停止当前的动作，保持静止站立姿态静止不动；APP 端同步弹窗示警。
- 软急停解除：确认机器狗与周围环境安全后，在 APP 端解除软急停，APP 和机器狗恢复正常状态。

C. 过热保护

- 机器狗具备全面的温度检测功能，一旦机器狗出现关节、主控、电池等过热时，机器狗将进入过热保护状态，机器狗将停止当前的所有运动，并趴下，保持不动；APP 端可查看过热的部位和温度，待温度降低到正常值后，可继续操作机器狗。

D. 低电量保护

- 当两块电池的电量均低于 20% 时，机器人会进入低电量预警状态，此时应立即充电；当两块电池的电量均低于 10% 时，机器人会触发低电量保护，它将自动趴下，不再响应手柄的遥控指令，请更换电池后再继续使用。

E. 摔倒保护

- 机器狗具备标准在摔倒之后，在强化学习运控模型的控制下，会尽量恢复站立状态；在周围环境不允许时，机器狗保持固定动作不变，并进行报警。

F. 扩展仓供电保护

- 扩展仓配备单独的电源按键，可以单独控制扩展仓的上电、断电情况。在整机上电情况下，需要更换上装载荷时，可以触发扩展仓按键，直接给扩展仓所有的接口断电，而不用给整机断电。扩展仓按键要在舱体里面，以避免在外被误碰，上装直接掉电。

载荷扩展

机器狗背部的空间平整，负载 30kg，背部部署有双导轨，支持上装载荷便捷安装，双导轨具体尺寸如下：

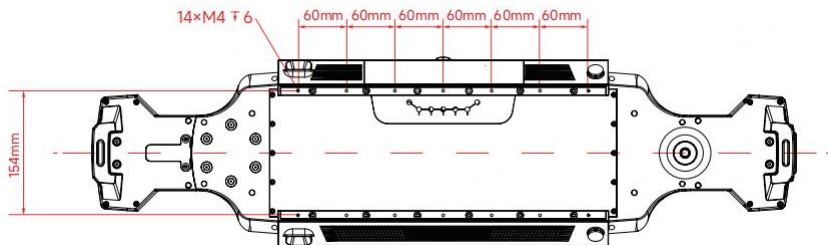

机器狗背留有扩展仓入口，上装载荷的供电通信线缆进入扩展仓与航插头对接，即可实现机器狗与上装载荷的供电和通信；



警示提示

- 机器人加装负载后，仅支持基础运动模式，请勿在加装负载后使用高台特技。
- 当在机器人背部加装载荷时，机器人的运动性能可能会受到影响，请务必在加装前向售后人员咨询相关事宜。
- 使用外接供电口对负载供电时，应注意，供电口可对外提供的总功率不超过 480W。
- 为保证 IP67，所有接口采用 IP67 航插头并有防护盖，未使用的航插接口请用航插口盖盖好。
- 在进行上装载荷安装时，在对接供电接口时，确保机器狗关机，或者扩展仓关机。

设备充电

机器狗电池充电

机器狗配备的双电池均采用插拔式快换设计，充电时只需要将电池拔下，通过配备双电池充电座和充电适配器对电池进行充电，具体操作如下：

A. 拔下电池

- 采用水平趴卧姿势，腹部完全贴紧地面，腿部自然放置于机身两侧，小腿呈完全收起状态，4 个膝关节与轮足平放在地面上；将电池侧的前 / 后腿依次抬起，为拔出电池留出空间。

- 也可在机器狗关机前，直接执行换电姿态，机器狗则自动水平趴卧，抬起电池侧的前后腿，为拔出电池留出空间。
- 轻拉电池手带，解锁电池卡扣，进而拔出电池，即可将电池从机器狗中取出。

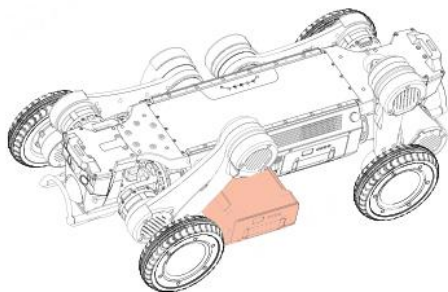

B. 充电准备

- 电池外观完好检查，确认电池没有鼓包、漏液等破损情况出现。
- 将充电座布置在硬质平面以保证放置平稳，充电过程中不会倾倒。
- 充电器接通 220V 交流电源，打开充电座船型开关，开关红色常亮显示充电座接通。
- 充电环境需干燥阴凉，远离易燃易爆物品，充电座周围的环境温度 0-50°C。

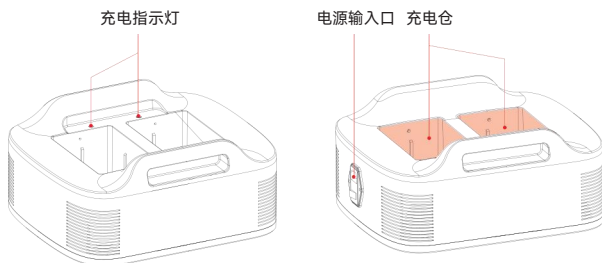

C. 电池充电

- 将电池与充电座的充电接口对准，插入电池座，电池座支持单电池充电和双电池充电。

- 确保充电座对应的电池充电状态的指示灯绿色常亮，处于稳定充电状态。
- 电池指示灯呈现流水灯状态，常亮的灯代表已充满对应的电量，频闪的灯代表正在充新的电量。
- 电池充满时，4 颗指示灯常亮，请及时拔下电池或者断开充电座电源；**充电时间不超过 6 小时。**
- 电池充满电被取下后，及时关闭充电座，以避免充电座插头带电，出现触电风险。

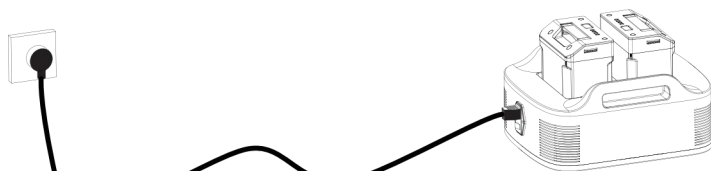

注意：禁止用第三方充电器、充电座对电池进行充电。

遥控器充电

当遥控器电量指示灯显示低电量时，对遥控器进行充电，如下图所示：

- 请使用原装 USB 充电器充电。
- 充电过程中遥控器的指示灯流水等状态，常亮的灯代表已充满对应的电量，频闪的灯代表正在充新的电量。
- 为保持遥控器电池最佳状态，请确保每一个月对电池进行一次完全充电。

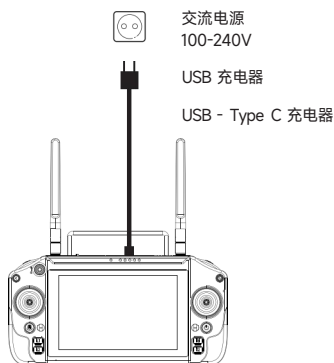

搬运

机器狗支持关机搬运和开机搬运两种搬运模式。

A. 关机状态搬运

- 机器狗按照水平趴卧姿势放置，腹部完全贴紧地面，腿部自然放置于机身两侧，小腿呈完全收起状态，4个膝关节与轮足平放在地面上。
- 搬运时，由两个人分别站在机器狗的头尾，双手抓取指定搬运点（小腿靠近膝关节的位置），将大腿和小腿向上提拉至关节限位，避免狗腿晃动，即可实现机器狗搬运。
- 搬运到目的地后，机器狗依然采用水平趴卧姿态放置于地面。

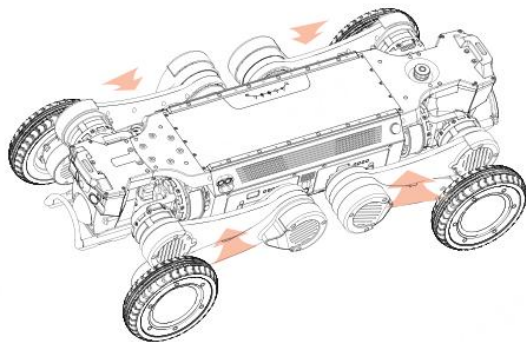

B. 开机状态搬运

- 机器狗开发了锁定姿态，在开机状态下，可将四肢锁定，因此1名工作人员可以双手抓住防撞梁，即可搬运机器狗。

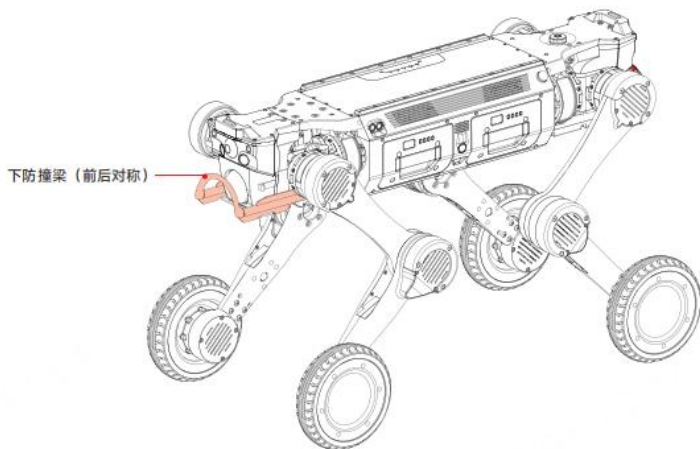

警示提示

- 搬运时注意机器狗的警示标识，以避免狗腿夹手。
- 机器狗开机或者刚关机时进行搬运，手部抓取位置尽量远离关节、电池；以避免电池、关节发热对手部烫伤。

存储

A. 存储前准备工作

- 环境准备：存储环境温度在 -20°C ~ 60°C 之间，干燥通风，需远离强磁场（如大型变压器、电磁铁等）和强振动源（如发电机、破碎机）。
- 清洁处理：去除机器狗机身、遥控器、电池、充电座表面进行，去除灰尘、污渍等杂质；注意避免液体进入机器狗的接口、散热孔等部位，防止内部元件受潮损坏。
- 状态检查：检查机器狗、遥控器、电池、充电座等确保外观无破损、功能状态完好。
- 电量调节：将电池电量充至 50% ~ 60%，此电量范围能有效避免电池因过度放电导致亏电损坏，同时防止满电长期存储造成电池容量衰减。

B. 各部件存储方法

- 机器狗存储：将清洁干净的机器狗关机，拔出电池，平稳放入专用包装箱内。

- 电池存储：将拆卸后的两个电池放在包装箱中，每个电池独立放置，避免多个电池相互挤压、碰撞，同时防止电池正负极与金属物品接触，避免发生短路现象。
- 遥控器存储：关闭遥控器电源，将遥控器放入专用的遥控器保护套中，一起放在包装箱中；避免遥控器受到剧烈撞击或挤压，防止遥控器外壳破裂、按键损坏或显示屏破碎。
- 充电器储存：将充电器放入专用的充电器收纳袋或包装箱内的充电器存储区域，确保充电器与其他金属部件隔离，避免充电器接口受到磨损或损坏；检查充电器插头是否完好，若发现插头有破损、生锈等情况，需及时更换后再进行存储。
- 包装箱存储：将包装箱折叠整齐，放置在干燥、通风的环境中，避免包装箱受潮发霉或被重物挤压变形，影响后续使用。若包装箱出现破损、承重能力下降等情况，需及时更换新的专用包装箱，确保设备存储和运输安全。

C. 存储期间维护与检查

a) 短期存储（1-3 个月）

- 每月对机器狗、电池、遥控器、充电器进行一次外观检查，确认各部件无损坏、变形、生锈等情况。
- 对电池进行一次电量检查，若电池电量低于 40%，需将电池充电至 50%-60% 后再继续存储。
- 检查存储环境的温度、湿度是否符合要求，及时更换失效的干燥剂。

b) 长期存储（3 个月以上）

- 每 2 个月对机器狗进行一次通电测试，将机器狗连接电源（或安装电池），开机运行 5-10 分钟，检查机器狗各功能是否正常，关节活动是否顺畅。
- 每 1 个月对电池进行一次充放电维护（将电池电量放电至 30%，再充电至 60%），防止电池出现记忆效应，保障电池容量。
- 每 3 个月对遥控器和充电器进行一次功能检查，测试遥控器按键灵敏度、充电器充电功能是否正常，若发现异常，需及时联系售后维修。

D. 存储注意事项

- 不得将机器狗及其配件倒置或倾斜存储，尤其是机器狗，倒置存储可能导致内部元件移位、损坏，影响设备正常运行。
- 存储过程中，不得在设备或包装箱上堆放重物，防止设备受压变形、部件损坏。
- 若需将设备从存储环境中取出使用，需先将设备放置在常温环境中静置 1-2 小时（若存储环境与使用环境温度温差较大），待设备温度与环境温度一致后再进行开机操作，避免因温差过大导致设备内部结露，损坏电子元件。
- 非专业人员不得在存储期间擅自拆卸机器狗、电池、遥控器或充电器，若发现设备故障或异常，需及时联系厂家售后人员，由专业人员进行检修，避免因自行拆卸导致设备损坏或安全事故。
- 存储相关的记录（如存储时间、检查时间、维护情况等）需做好详细登记，便于后续追溯设备存储状态，及时发现并解决潜在问题。

遥控操控说明

图示

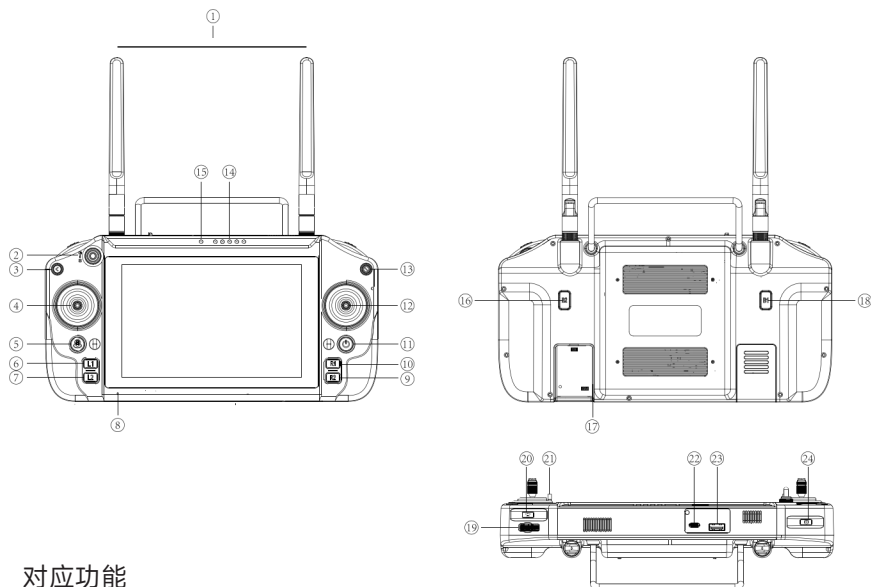

对应功能

序号	按键	序号	按键
①	2.4G/5.8G 天线	⑬	软急停
②	/	⑭	遥控器电量指示灯
③	返回	⑮	对频指示灯
④	左摇杆	⑯	按键 B2
⑤	按键 H	⑰	SIM 卡插口
⑥	L1 按键	⑱	按键 B1
⑦	L2 按键	⑲	波轮
⑧	麦克风	⑳	补光灯
⑨	按键 R2	㉑	挂绳处
⑩	按键 R1	㉒	TYPE-C 接口
⑪	开关机	㉓	USB 接口
⑫	右摇杆	㉔	拍摄 / 录制视频按键

功能使用详情

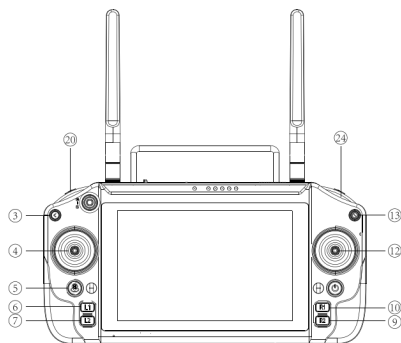

按键功能	按键操作	功能定义
返回上一层	点按“返回”(③)	返回上一层级页面
控制机器狗前后左右移动	推动“左摇杆”(④)	速度跟据推杆力度逐渐增加, 拉到最底部是设置的每个档位的上线
原地转弯	推动“右摇杆”(⑫)	推动右摇杆, 控制机器狗原地转弯
运动时转换方向	左摇杆 + 右摇杆(④ + ⑫)	左摇杆控制移动, 右摇杆控制移动方向
水平转身	原地模式 + 右摇杆左右推动(⑫)	原地模式下, 左右推动右摇杆, 执行左右探头动作
高低身形	原地模式 + 右摇杆上下推动(⑫)	原地模式下, 上下推动右摇杆, 执行俯仰动作
左右探头	H+ 右摇杆左右推动(⑤ + ⑫)	H 与右摇杆左右同时推动, 执行水平左右转身动作
俯仰身形	H+ 右摇杆上下推动(⑤ + ⑫)	H 与右摇杆左右同时推动, 执行高低身形动作
机器前后向切换	同时短按: L1+R1(⑥ + ⑩)	机器方向角度切换
膝关节模式切换	同时短按: L2+R2(⑦ + ⑨)	同膝模式 / 内对膝模式切换
软急停	点按“软急停”按键(⑬)	机器停止运动
拍照	点按“拍摄键”(⑭)	拍照
录像	长按 3s “拍摄键”(⑭)	长按 3s, 录制视频, 再次点按取消
开启 / 关闭补光灯	点按“补光灯键”(⑳)	每次单击按照“两个补光灯开启 - 前开后关 - 后开前关 - 全关”的逻辑进行循环

APP使用说明

机器狗与遥控器连接

- 确保连接前，机器狗在遥控器附近
- 机器狗开机后，长按遥控器开机键开机
- 点击并打开“GenisDog”APP，等待遥控器与机器狗自动连接

主功能介绍

点击“进入主页”



使用“GenisDog” APP 操作或设置机器狗

A.主页面功能显示



B.模式切换

根据您的任务场景，选择适合的功能模式



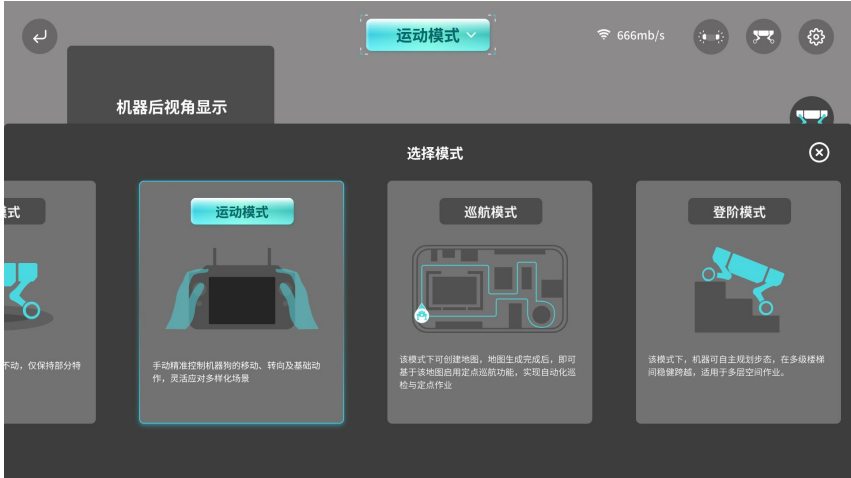

a) 原地模式

- 功能描述: 机器狗将锁定移动功能, 在原地保持稳定站姿。
- 核心用途: 专注于执行特技动作、进行精准调校或进行设备检查。
- 场景: 开机自检、调试标定等。

b) 运动模式 (默认)

- 功能描述: 解锁全部移动能力, 通过手动遥控, 精准控制机器狗的全向移动、转向及基础动作。
- 核心用途: 在复杂环境下进行灵活、精细的手动操控。
- 场景: 复杂地形穿越、狭窄空间探索、特定目标抵近观察等。

c) 巡航模式

- 功能描述: 在此模式下, 您可以先引导机器狗构建环境地图。建图完成后, 即可基于该地图设置定点任务, 启动自动化巡航与作业。
- 核心用途: 实现自主化、可重复的巡检与作业任务, 解放人力。
- 场景: 自动化巡检、预设路线巡逻等。

d) 登阶模式

- 功能描述: 该模式下, 机器可自主规划步态, 在多级楼梯间稳健跨越。
- 核心用途: 高效执行跨楼层任务。
- 场景: 多层楼宇巡检。

C. 设置界面



- a) 自动开启补光灯：根据环境光线强度，自动开启或关闭前置补光灯，确保在暗光环境下也能获取清晰的视频画面。
- b) 自动停障：开启后，手动控制机器运动时，识别到障碍物将自动停止前行。适用于在复杂场景下的手控防撞。
- c) 辅助姿态：
 - * 换电姿态：需要更换电池时触发，机器狗将调整至特定姿态，方便插拔电池。
- d) 设备信息：查看机器狗的核心信息，包括设备序列号以及各子系统（如主控、运动、视觉）的软件版本号。

软件持续升级声明：

本产品配套的应用程序（APP）将进行定期迭代与功能更新，因此说明书中的描述可能与最新版本存在差异。我们致力于持续优化用户体验，具体功能请以 APP 内实际呈现为准。

常见问题	处理措施
无法开机，启动失败	轻按电池开关，检查电池电量； 重新安装电池：确保电池与机身接口对齐，听到“咔哒”声表示安装到位； 清洁接口：用干布或橡皮擦擦拭电池与机身的金属触点，去除氧化层。
遥控器连接异常怎么办？	先确认机器人是否开机正常，若正常看急停状态是否已关闭，若未关闭，请先排查故障，排查完成后再关闭急停状态；若急停状态已关闭且依然无法操控机器人，请重启机器人。若仍有异常，请联系售后。
机器人开机站立姿态异常，是否还能继续使用？	此时不要控制机器人移动，请立刻按下软急停使机器人趴下，关机重启，再次尝试操控机器人站立。若仍有异常，请联系售后。
图传画面模糊 / 无信号	用镜头布轻擦摄像头表面，去除灰尘和污渍； 优化信号环境，避开 Wi-Fi、蓝牙等强干扰源，将控制端与机器人距离缩短至 10 米内； 关闭机器人和控制端，重新启动后测试图传。若重启后仍无信号，请联系售后。
机器人可以适应哪些地形？	机器人可适用于平地、草地等起伏较为平缓的地面，也可攀爬楼梯、斜坡等复杂地形，但请避免在极端地形（如冰面等过于光滑的表面、尖锐或起伏较大的地形、高处边缘等）中操作和使用机器人。
遇到查阅本手册后依然无法解决的问题时该如何处理？	保存数据并及时联系售后。

A. 日常清洁规范

使用机器后，若表面有污渍请及时清洁机身表面，擦拭机身前请先关闭电源，使用干燥且干净的软布对机身进行擦拭，尤其关注相机和雷达是否擦拭干净并注意避免用硬物刮擦镜头。

清洁过程中禁止使用酒精、消毒液等腐蚀性液体擦拭。

B. 定期检查维护

为保障机器狗运行稳定性、延长设备使用寿命，需定期开展预防性检查与针对性维护。

维护周期	维护模块	具体维护项目
日常检查 （每次使用前， 约 5 分钟）	外观与结构	检查机身、腿部连杆有无变形、裂纹； 检查关节、足部固定螺丝是否松动； 检查足部轮胎有无脱落、严重磨损（纹路磨平），若有请及时更换。
	电池与供电	检查电池外壳无鼓包、漏液； 电池安装是否可靠，确保运行时不会松脱； 通过设备屏幕 / APP 查看电量（低于 20% 需充电）；
	功能测试	启动设备，操作摇杆测试各关节活动是否流畅， 有无卡顿、“咔咔”异响； 检查摄像头、传感器镜头无遮挡，图传画面清晰； 测试 10 米内遥控信号是否稳定（无延迟）。
每周维护 （每周 1 次，约 20 分钟）	整机保养	用干软布擦拭机身外壳（油污处可蘸少量清水轻擦）； 用镜头布轻擦摄像头、激光雷达表面灰尘； 用毛刷清理传感器周围缝隙杂物； 用镊子清理轮胎缠绕的杂草、线头，避免卡顿。
	关节与传动系统	用干燥软布擦拭所有关节的表面及缝隙，清除泥沙、灰尘；涉 水后用吹风机低温档吹干轴承处； 手动活动各关节，确认无卡顿、异响，螺丝无松动，线缆无缠 绕磨损。
	电池维护	将电池完全充满后再使用（避免长期充至 80% 以下存放）； 每 3 周进行 1 次“满充 - 满放”（完全充满后使用至 20% 以 下再充电）。

每月维护 (每月 1 次， 约 30 分钟)	软件更新	通过配套 APP 或官网检查固件更新； 按提示下载并安装更新（升级期间确保电量 $\geq 50\%$ ，勿断电）。
	部件状态评估	每月检查关节连接件（如机械臂转轴、腿部轴承），若发现松动需用专用扳手拧紧； 部件状态评估：每月检查轮胎磨损状态，如有破损，请及时更换； 每 3 个月检查电池健康度（通过设备配套 APP 查看循环次数，超过 500 次建议更换）。

注意事项

- 维护时需关闭设备电源，避免误操作导致损伤。
- 更换备件（如轮胎、电池）请使用原厂配件，非原厂配件可能影响设备安全。
- 如遇复杂故障（如关节卡死、传感器失灵），请勿自行拆解，联系售后技术支持。

A.您购买的产品主要部件保修时间如下表所示:

部件名称	保修期
整机	1年 / KM
主板	12个月
关节模组	7个月
电池	6个月 /200次循环

注：外壳、足部轮胎等易损件及运输箱等配件不在保修范围，如有需要，请咨询售后支持。产品针对不同零部件提供不同的保修期限并设置了公里数限制。产品的行驶公里数和特定零部件的保修期，二者任一标准超出上表限值，保修将自动转为有偿维修。

您购买本产品后，保修期自您签收货物当日算起，为保护您的权益，请您在签收产品时务必当场检查确认产品及其随货物品 / 资料处于完好或正常状态，否则请立即联系乙方。根据物流公司的理赔要求，因物流运输导致的物品损坏，需在发现物流致损事件的24小时内联系售后部门解决，逾期将无法为您受理。

B.免费售后服务的例外情形以下任一情形，将使您处于保修期内的产品丧失免费售后服务的权利，但您仍可在具备可能性的前提下选择有偿售后服务；

- 发生非产品本身质量问题（例如：人为原因等）导致的碰撞、跌落、烧毁等损坏；
- 产品进行二次开发（不论是否事先得到授权）或硬件改装、拆解等行为；
- 擅自维修部件、电路改造、电池组改造、充电器使用不当导致的损坏；
- 产品因浸入液体、杂物、接触化学物质、划伤等原因导致的损坏；
- 超过产品安全载重限值情况下使用造成的损坏
- 产品长时间搁置不用导致的损坏；
- 未按产品说明书的要求进行激活、安装、使用所造成的损坏；
- 使用非原厂配件（包括但不限于替换、加装等情形）导致的产品故障或损坏；
- 因操作失误 / 故意导致产品撞击硬物、跌落，以及产品表面存在明显摔打、碰撞或划伤痕迹等情况；

- 因不可抗力或极端恶劣环境（包括但不限于强磁 / 强干扰 / 高温 / 低温 / 自然灾害）导致的损坏；
- 在地形尖锐、起伏较大、光滑地面等环境操作导致的损坏。

C.送修说明；

- 联系获取售后服务时，请详细说明产品存在的问题。将先尝试通过电话、电子邮件、远程协助等方式诊断并解决您的问题。
- 如上述方式难以解决您的问题，您可将产品寄送乙方进行进一步检测，然后据此作出相应安排或决定。如经检测不符合免费保修政策，您可选择有偿售后服务（届时乙方将与您确认有关售后项目和收费）或原机退回。
 - ※ 您在将产品寄往乙方时需先行承担邮寄费用。
 - ※ 乙方收到寄回产品后，将对产品进行故障检测以确定问题责任。若经检测属于产品本身质量缺陷且在保修期内，相关费用及寄回的快递费将由乙方承担。
 - ※ 若产品经过检测不符合免费维修条件，您可以选择付费维修或将问题产品寄回。乙方会与您确认维修方案，如接受，则甲方按照确认的维修方案支付所有费用；如无法接受，则设备退回甲方，由此产生的相关检测费、人工费、运费等由甲方承担。
 - ※ 如产品本体、充电器、遥控器发生进水情况，会严重影响产品性能，且不具备维修价值，故乙方无法提供维修服务，但可视情况提供有偿更换产品服务，请知悉并酌情寄回。



智元机器人

“
成为智能机器人
全球领军企业
开创通用机器人生态

To Become a Global Leader
in Intelligent Robots
and Create a General Purpose
Robot Ecosystem

”



微信公众号



官方网站

AgiBot D1 Max

User Manual



- 1. Version Statement
 - 01 Legal Statement
 - 02 Precautions
- 2. Product Introduction
 - 01 Product Overview
 - 02 Component Name
 - 03 Core Spec
 - 04 Description of Light Effect
 - 05 Expansion Interface
 - 06 Mode of Motion
- 3. Instructions of Robot Dog
 - 01 Environment Requirement
 - 02 Unpacking
 - 03 Pre-start Inspection
 - 04 Pre-start Preparation
 - 05 Startup and Operation
 - 06 Battery Swapping and Power-Off
 - 07 Emergency Stop and Protection
 - 08 Payload Expansion
 - 09 Charging
 - 10 Transporting
 - 11 Storage
- 4. Instructions of Remote Control
 - 01 Instructions for Remote Operations
 - 02 Instructions of APP
- 5. Anomalies and Solutions
- 6. Daily Maintenance
- 7. Warranty Policy

Legal Statement

Before using this product, users must carefully read the user manual and operate the product strictly in accordance with its contents. The company shall not be held liable for any property damage or personal injury resulting from the use of the product in violation of the instructions in this manual. This product consists of multiple components. Please ensure that children cannot access the product to avoid accidents. This product is only for use by persons aged 18 and above. To extend the product's service life, do not use it in high-temperature or high-pressure environments. This manual aims to include functional descriptions and usage instructions for the product as comprehensively as possible. However, due to continuous improvements in functionality and design changes, there may be discrepancies between the actual product and the manual content. If there are differences between the actual product and this manual in terms of color, appearance, etc., please refer to the actual product.

This manual applies to the D1 Max version (Model: ZYCXD125M).

A. Application of Robot Dog

- **Terrain:** Please try to avoid walking on smooth surfaces such as glass or ice; if walking is necessary, try to reduce the robot dog's walking speed to prevent slipping and falling.
- **Climate/Weather:** Please avoid deploying the robot dog in severe weather conditions such as heavy fog, thunderstorms, sandstorms or strong winds whenever possible.
- **Communication Interference:** Please Do Not operate the robot dog in any environment with severe communication signal interference from sources like WiFi or RF; if necessary, be sure to turn off the interference sources or reduce their interference.
- **Electromagnetic Interference:** Please Do Not operate the robot dog in environments with strong electromagnetic interference, such as near high-voltage power lines, high-voltage substations, communication base stations or signal towers. If necessary, please consult our after-sales service first.
- **IP Protection:** The robot dog has a protection rating of IP67, allowing it to walk 1m underwater for 30min. Before application of functions, be sure to keep the robot dog in proper condition, including keeping its exterior undamaged, the expansion port cover securely closed, and the battery and its compartment dry and free of moisture; after completing the 30-min walking underwater, promptly remove the robot dog from the water, thoroughly wipe and dry its body, and perform any required maintenance before the next operation underwater. Any malfunction of the robot dog caused by prolonged water immersion and so on may void the warranty.
- **Maximum Speed:** The robot dog can reach the maximum speed of 6m/s, with significant impact force; therefore, at any high speed, please be sure to keep the robot dog away from crowds.
- **Mode of Motion:** The modes of motion of robot dog are divided into Stationary Mode, Sport Mode, Navigation Mode and Stair Climbing Mode. Please switch between different Mode of Motions according to the environmental scenario in the process of use.
- **Recovery from a Fall:** The robot dog requires space to regain its standing posture after a fall. To avoid collisions, please ensure no persons or objects within the 2m extent around the robot dog; and Do Not drag a fallen robot dog when its hard emergency stop has not been triggered.

B. Battery Application

- If the battery emits a noticeable odor, shows signs of overheating or exhibits corrosion before initial use, please contact the battery supplier.
- Before allowing children to use the equipment, adults must clearly explain how to use the equipment and the battery, and periodically follow up to confirm and ensure their proper use.
- Please Do Not use or place the battery in an extremely high temperature (e.g., over 60 °C, such as under intense direct sunlight or inside an extremely hot vehicle), otherwise, the battery may be overheated or even catch fire, its performance may degrade and its service life may be shortened.

- Please Do Not use the battery in any environment with electrostatic discharge over 1,000V, as this may damage the protection circuit and create a safety hazard.
- The battery can only be charged within the temperature range of 0 to 50°C. Charging outside this temperature range may cause the battery to leak liquid, overheat or severe damage. This may also cause degradation of the battery's performance and lifespan.
- Please Do Not charge or discharge the battery near anything flammable, as this may create a fire hazard.
- The battery will automatically enter the storage mode upon a single-cell under voltage condition is detected. In this mode, the battery will make no response to the power switch and the battery indicator light will be kept normally off. The battery can exit the storage mode after being charged.
- Once powered off via the battery button, the battery will enter the sleep mode and can be awakened by communication, pressing the button or charging.
- If the battery circuit terminal has become dirty, please wipe it clean with a dry cloth before use; otherwise, poor contact may lead to performance failure.
- The battery should be stored at room temperature and charged to 30%~60% of its capacity. To prevent the battery from being over-discharged, it is recommended to charge the battery to 50% with the standard charging method once every 3 months; if the battery has been stored for over one year, it is advised to perform one full charge-discharge cycle annually with the standard method to activate the battery.
- A battery, if left unused for an extended period, may be in an over-discharged state due to its own self-discharge (below the over-discharge protection voltage or the over-discharge voltage of cell), or even the cell may be discharged to 0V. Continued use of such battery may carry risk. To prevent over-discharge, please be sure charge the battery regularly to maintain its voltage between 30% and 60% of its capacity.
- The plug cord has limited tension resistance and excessive pulling force may damage the battery. Once the battery is installed into the machine, be sure not to swing the battery and the plug cord freely.
- Do Not use or store the battery near fire or a heater or in high-temperature environment (>80°C).
- The use of any unauthorized charger is prohibited and any damage to the battery caused thereby is not covered under warranty.
- Do Not connect the battery with reversed polarity nor short-circuit the battery by directly connecting the positive and negative terminals with wires or any other metal objects.
- Do Not incinerate or heat the battery nor cause any excessive mechanical shock on the battery such as striking, throwing or stomping. Do Not pierce the battery with nails or any other sharp objects.
- Do Not disassemble the battery, since disassembling will void the warranty!

C. Other Precautions

- If the robot dog shows signs of water ingress, immediately turn off its power, remove the battery and allow it to dry thoroughly.
- If the robot dog smokes or catches fire, prioritize using fire extinguishers such as carbon dioxide or dry powder. Do Not use foam fire extinguishers.
- If the robot dog exhibits uncontrolled motion such as leg swinging, prioritize triggering the soft or hard emergency stop and ensure the safety of personnel, then power off and remove the battery before proceeding with troubleshooting; in case of any knotty problems, report them to our technical support officers for troubleshooting, equipment repair or replacement.
- Unauthorized disassembly of the robot dog is prohibited. Warranty will be voided if disassembled!

Product Overview

D1 Max is a wheel-legged quadruped robot featuring lightweight design, high load capacity, long endurance, strong protection, and flexible, stable movement. Each leg of the robot dog is equipped with 3 joint motors and one hub motor, supporting wheeled/ pointed leg replacement. It is equipped with sensors such as LiDAR, optical cameras, ultrasonic radar, IMU, fill lights and RTK modules; internally incorporating a high- performance main platform for motion control, autonomous navigation and positioning, environmental detection and the like function, providing a rich set of power supply and communication interfaces, supporting the expansion of multiple categories of mission payloads.

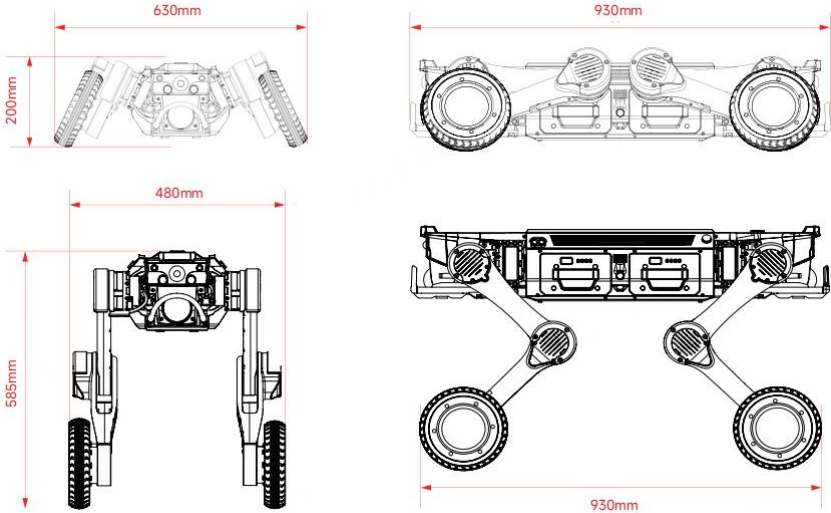

Component Name

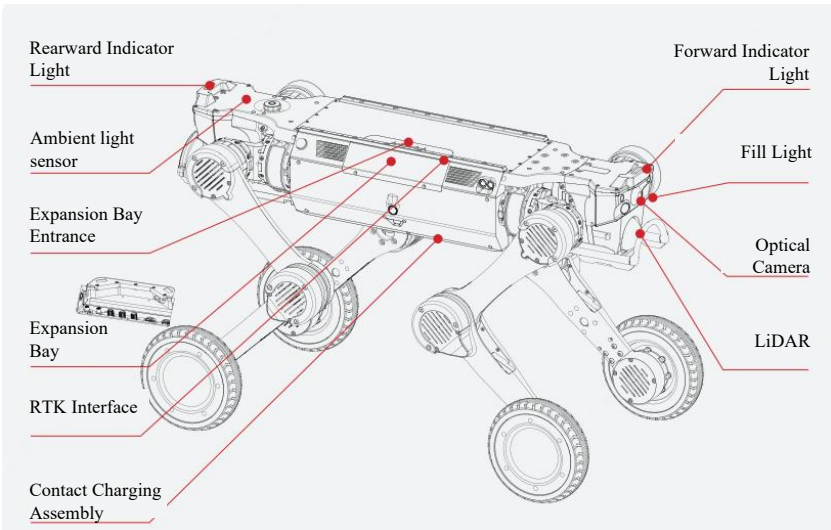
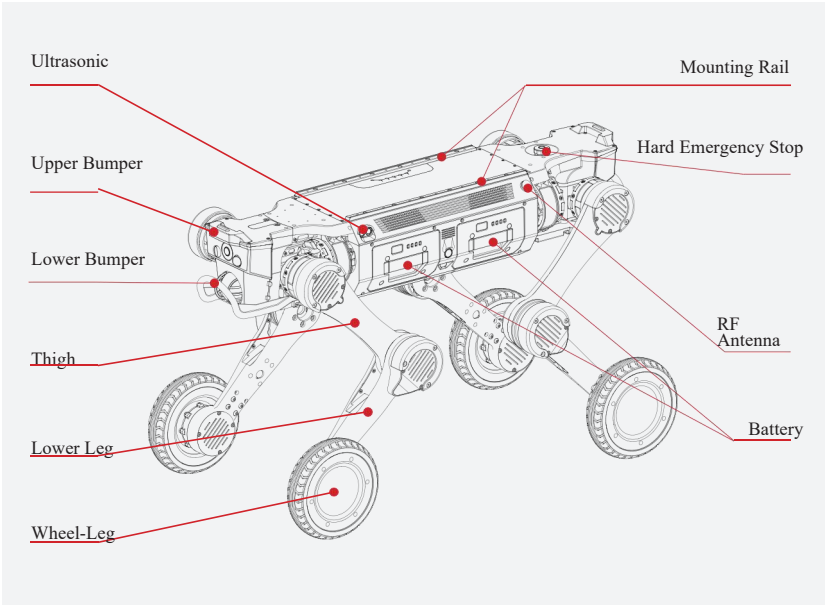

Core Specification

Category	Specification	Description
Basic Information	Product Model	ZYCXD125M
	Material	Aluminum Alloy + High-Strength Engineering Plastic
	Size (Standing)	930mm*480mm*585mm
	Size (Lying Prone)	930mm*630mm*200mm
	Machine Weight (with battery)	41kg
	Battery Weight	3.3kg/pc
	Wheel Size	8 inches
	Ingress Protection	IP67
	Operating Temperature	-20°C ~ 55°C
Motion Performance	Degrees of Freedom	12+4dof
	Max Speed	8m/s
	Effective Payload	25kg
	Max. Climb Angle	45°
	Continuous Climbable Step Height	25cm
	Minimum Passing Width	50cm
	Vertical Obstacle Crossing Height	80cm
	Horizontal Obstacle Crossing Distance	80cm
Battery Parameters	Battery Capacity	54V, 9.35Ah*2, dual batteries that support quick replacement with hot-swap capability
	No-Load Runtime	5h
	Full-Load Runtime	3.5h
	No-Load Range	29km
	Full-Load Range	18km
	Charging Dock Input Voltage	AC220V
	Charging Dock Output Voltage/Current	DC63V, Max Charging Current 10A
	Charging Time	≤ 2h per battery (charging dock supports dual-battery simultaneous charging)

Notes:

- (1) Charging time data is measured under a standard ambient temperature of 25°C.
- (2) Mileage range data is measured at a speed of 1m/s under no-load conditions.
- (3) For instructions on using the functional expansion interface, please refer to the expansion manual.
- (4) For detailed warranty terms, please refer to the product warranty manual.
- (5) The above parameters are laboratory test data. Actual performance may vary due to usage environment, operation methods, and other factors. Please refer to the actual product performance.

Description of Light Effect

Status Indicator

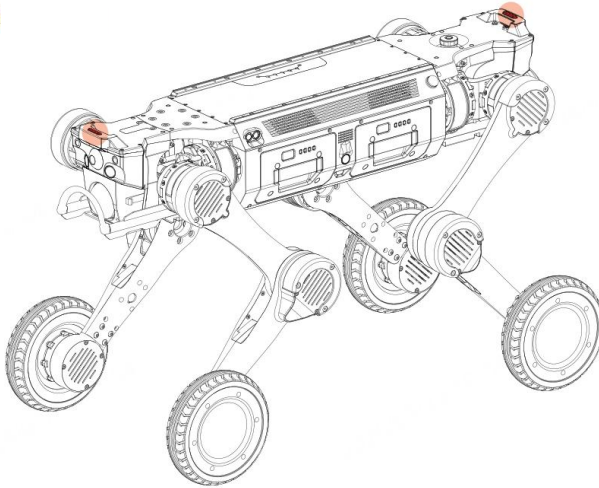

Indicator Color	Indicator Effect	Robot Dog Status
White Light	Slow Flash	Startup in progress
	Normally On	Manual Control/Machine Work State
	Breathe	Standby
Green Light	Slow Flash	Locating/Auto Return in Progress
	Normally On	Auto Task Execution in Progress
Yellow Light	Quick Flash	Alarm State
	Normally On	Low Battery
Red	Quick Flash	Fault State
	Normally On	Soft Emergency Stop
Blue Light	Normally On	Upgrading
/	Breathing State	Charging (Optional Charging Pile)



Warning Prompt

- Hard Emergency Stop: the red light of the indicator is normally ON and the red light of the hard emergency stop button is normally ON.
- Forward/Reverse Direction Switch: When the robot dog switches between forward and reverse directions, the status light on the corresponding direction will be illuminated, followed by the execution of the aforementioned lighting effect.
- Except when switching between the forward and reverse main direction states, where the front and rear lights differ, they are consistent in all other situations.

Description of Light Effect

Battery Indicator Light

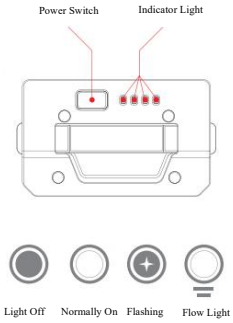
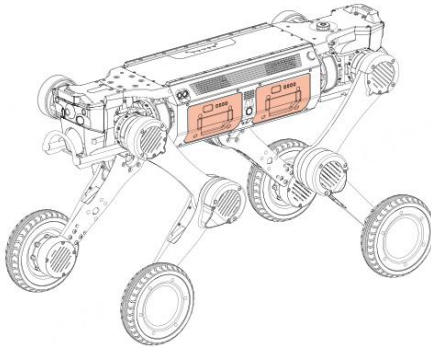

Battery Indicator Light Effect	Description of Light Effect	Battery Level Description
	4 LEDs normally ON.	Battery Level 75%~100%
	The first 3 LEDs are normally ON.	Battery Level 50%~75%
	The first 2 LEDs are normally ON.	Battery Level 25%~50%
	The first LED is normally ON.	Battery Level 0%~25%
	The first LED is flashing.	The battery level is 0%.
	4 LEDs are illuminated in sequence.	"Charging" is displayed and all 4 LED indicators stay lit when fully charged.

Emergency Stop Indicator

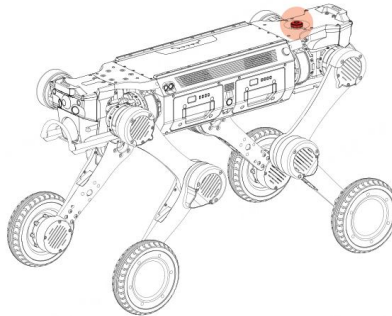

Light Off	Hard Emergency Stop Not Triggered
Red Light Normally On	Hard Emergency Stop Triggered

Expansion Interface

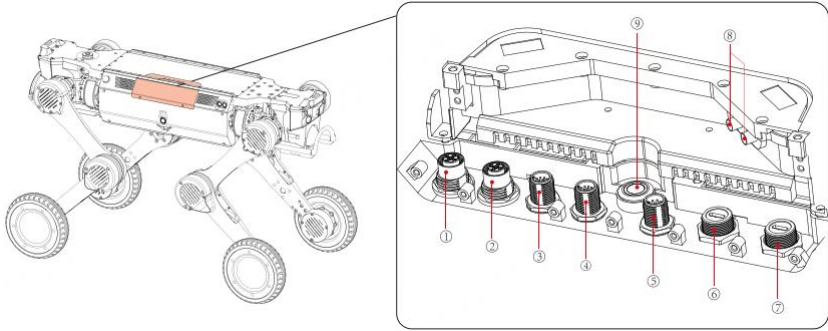

SN	Interface Name
①	48V (10A) x1
②	24V (20A) x1
③	24V (3A) + 1xEthernet Port
④	12V (5A) + 1xEthernet Port
⑤	Serial Port (RS232 x1, RS485 x1, SBUS x2 and PPS x1)
⑥、⑦	2xUSB3.0 (5V and 1A)
⑧	RTK Interface
⑨	Expansion Bay Button

Warning Prompt

- When installing additional equipment on the back of the robot dog, regarding the planning and design of its center of gravity, position, interface and wiring, please consult our after-sales service staff before proceeding with the formal installation;
- The total power supplied by all power interfaces is $\leq 480W$;
- If an aviation plug is used, a protective cap shall be equipped to ensure IP67 rating; the protective cap shall be secured if the aviation plug is not used.
- The expansion bay button is used to control the power supply to the expansion interface; when connecting assemblies, be sure to power off the expansion bay first.

Mode of Motion

The robot dog comes standard with an Reinforcement Learning Locomotion Model, featuring Stationary Mode, Sport Mode, Navigation Mode, and Stair Climbing Mode.

Stationary Mode	The robot dog remains stationary while its torso performs various actions including rotation, pitch, and height adjustment.
Sport Mode	The robot dog can automatically adapt to flat ground, slopes, stairs, and various complex terrains such as mountains, forests, and rubble. It supports forward and backward movement, in-place rotation, and can perform standing, crawling, prone, and locked postures, as well as advanced maneuvers like climbing elevated platforms and twisting motions.
Navigation Mode	In this mode, maps can be created. Once the map is generated, the fixed-point cruise function can be enabled based on the map to achieve automated inspection and fixed-point operations.
Stair Climbing Mode	In this mode, the robot dog autonomously plans its gait to traverse multi-level staircases with stability, suitable for multilevel space operations.



Warning Prompt

- When performing high-platform climbing stunts, ensure the robot dog has ≥ 2 battery bars and is unloaded, keep it in sight and maintain a safety distance of ≥ 2 meters from bystanders.
- When navigating stairs, slopes, or similar surfaces, ensure no one is directly above, below, or within the robot's path.
- In Motion Mode, the robot dog features standard low, medium, and highspeed settings. To ensure safe task execution, lateral movement and in-place rotation are restricted during medium and high speeds.

Environment Requirement

- Before performing the power-on operation, the operator shall thoroughly read this manual to familiarize himself/herself with all functional states, operational details and precautions of the robot dog;
- In the process of initial operation, try to avoid the robot dog moving out of sight and ensure no person nor obstacle within 2m around it so as to prevent collision;
- Temperature Required: Please be sure use the robot dog within an ambient temperature range of -20°C to 55°C;
- Weather Required: please Do Not power on and use the robot dog in severe weather conditions such as heavy fog, thunderstorms, sandstorms, tornadoes, etc.
- Electromagnetic Environment Required: Avoid using the robot dog in environments with strong electromagnetic interference (e.g., high-voltage power lines, high-voltage transmission substations, communication signal towers, etc.) to prevent magnetic breakdown;
- Communication Environment Required: please Do Not power on and use the robot dog remotely in environments with communication signal interference to avoid its communication disruption and loss of connection.

Unpacking

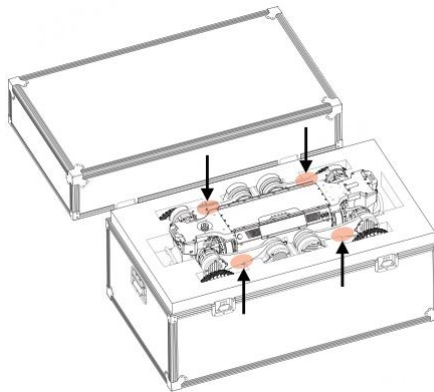

The robot dog is packed in a flight case, so please place the case on a flat surface with the correct orientation upward; open and remove the lid; then, sequentially remove the robot dog, battery, remote control, charger cradle, etc., and place them on a hard and flat surface.

**Warning
Prompt**

- When moving out the robot dog, hold the designated lifting points shown in the diagram as instructed, and pay close attention to the location and content of warning labels to avoid pinching or scratching hands in the process of transporting;
- Handle the robot dog, battery, remote control and charger cradle gently in the process of transporting;
- After the transporting is completed, check and make sure that AGIBOT D1 Max's emergency stop button, battery power button, etc., have not been triggered.

Pre-start Inspection

A. Appearance and Mechanical Structure Check

- Overall Exterior Integrity: Check the body shell for cracking, deformation or detachment, focusing on vulnerable parts like joint connections and sensor protective covers; observe whether there are obvious stains, liquid residue or foreign matters on the body surface, especially around radiator holes and interfaces.
- Joint and Moving Part Check: Check each of the robot dog's leg joints and wheel legs one by one to confirm that the joint motion is smooth, without signs of sticking, abnormal noise or looseness. For wheel-legs/point-legs, confirm that the anti-slip tread is clear, without cracking or peeling. Confirm that fasteners such as screws and clips at the joints are not missing or loose.

B. Battery Status Check

- Battery Appearance: Check whether the battery pack shell is bulging, leaking or damaged; bulging may indicate that the battery is aged or overcharged, so please Do Not use any batter aged or overcharged but make replacement immediately to avoid fire or explosion risk.
- Battery Connection: Check whether the connection interface between the battery and the body is clean, free from oxidation, corrosion or foreign matters; ensure the latch is fastened securely when inserting to avoid power interruption due to poor contact.
- Battery Level Check: Before power-on, you can initially judge the battery level via the indicator, on which, at least one battery should have more than 2 bars of charge; click the battery power button to display the exact charge level; in a low-battery state, charge first to avoid mid-operation shutdown due to insufficient power after startup, which could affect the lifespan the equipment.

C. Environmental Perception Sensor Check

- Optical Sensor: Check whether the lenses of its cameras and LiDAR are clean, free from stains, scratches or obstructions.
- Distance/Obstacle Avoidance Sensor: Check whether the probes of obstacle avoidance components like ultrasonic sensors are intact and unobstructed or not.

D. Remote Control Check

- Check whether the remote control button is responsive without sticking, and whether the battery has sufficient charge (indicated by the indicator of the remote control) to ensure normal operation of the robot dog once powered on.
- Check the body's display screen, indicator lights, speakers and the like feedback components; confirm that the display screen is undamaged and free of distortion, and that the indicators can be illuminated normally for facilitating timely acquisition of its operating status (e.g., battery level, fault warning) once powered on.

Pre-start Preparation

A. Install the Battery

The robot dog is equipped with dual battery compartments, supporting both single battery and dual-battery power supply modes, so please align the battery with the battery interface of the compartment (featuring foolproof design to prevent incorrect insertion), pull up the battery's hand strap, push the battery into the compartment till bottomed out, then release the hand strap; a "clatter" sound heard means that the latch is locked. Once installed, please check the battery installation status. The outer surface of the battery should be kept flush with the surface of the robot dog body.

B. Place the Robot Dog

Adopt a horizontal prone posture, i.e., abdomen fully flush with the ground, legs naturally positioned on either side of the body, lower legs in a minimally retracted stance, with all 4 knee joints and wheel feet flat on the ground, to keep no thigh or lower leg compressed by the torso.

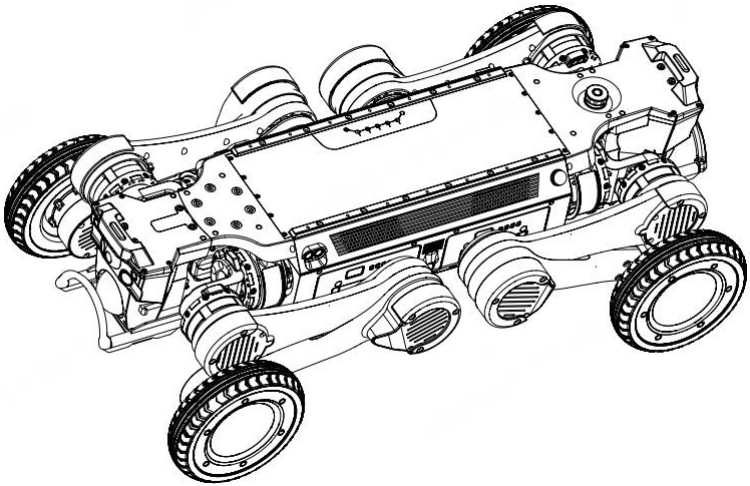

Startup and Operation

A. Robot Dog Power-On Process

The power-on process for the robot dog is initiated through its battery and the specific procedure is as follows: briefly press the battery button to activate the battery, the indicator of which will be normally on and display its current charge level, then, press and hold the battery button for 3s to turn on the battery and boot up the robot dog. A white blinking status indicator signifies the startup in progress, while a steady white light indicates that the startup is completed and the robot dog has entered the Mode of Universal Motion.

The robot dog can be supplied power by single-battery and dual-battery. The specific power-on procedures are detailed as follows

Robot Dog Battery Status	Power-On Process Flow
When the robot dog is powered off and no battery is inserted	Insert only one battery: Either directly insert a battery once powered on, or first insert a powered-off battery and then power on the battery to start the robot dog;
When the robot dog is powered off and a powered off battery is inserted	Insert another powered-on battery to start the robot; for an inserted powered-off battery, it will be automatically started 1 min after insertio; Insert another powered off battery to start any one battery and power on the robot dog;
When the robot dog is powered off and 2 powered off batteries are inserted	Either battery can be powered on to start up the robot dog as a whole. The other battery will be automatically engaged without the need for manual activation.



Warning Prompt

- Dual batteries feature mutual wake-up functionality. In dual-battery mode, only the states of both batteries ON or both OFF are supported; a state with one battery ON and one OFF is not supported;
- When D1 Max is powered on with a single battery, inserting another powered-on/off the battery will automatically activate and connect such battery.

B. Power on the Remote Control

If you press and hold the power button of remote control, the remote control screen and power indicator will be illuminated; since the remote control is paired one-to-one with the robot dog before it is delivered from the factory, it will be automatically connect with the robot dog upon startup.

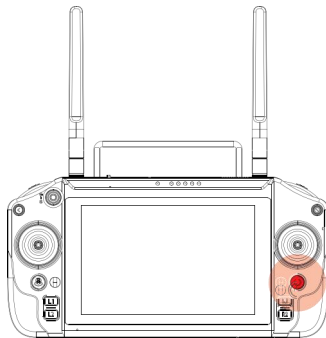

Once the remote control is turned on, click the APP icon on the screen to enter the APP control interface. Once the health status of APP is confirmed, you can proceed to control the robot dog.

C. Operation Guide

For remote control operation, please refer to the Genisom M1 Remote Controller User Manual.

D. First Power-On Verification

- **Basic Motion Test:** Use the APP of the remote control to command the robot dog to perform simple actions such as standing, going prone, moving straight forward/backward/leftward/rightward and turning; confirm that the joint can move freely; in case of jerking, abnormal noise or inability to stand, power off immediately and check for joint jamming or incorrect posture.
- **Sensor Status Test:** All sensors of vision, laser, ultrasonic, and inertial navigation can function normally and data can be displayed properly on the APP.
- **Status Feedback Check:** Observe the equipment status indicated by the LED, LCD or the APP to confirm normal battery level, connection signal, firmware version, etc. If any fault prompt has appeared, be sure to shoot the trouble according to the operation manual.

Battery Swapping and Power-Off

A. Change the Battery

The robot dog features dual batteries with hot-swap capability. When powered by both batteries, you can directly unplug one powered-on battery and replace it with a battery in either an ON or OFF state; the robot dog can be maintained operating normally in the process of battery changing and powered by dual batteries;

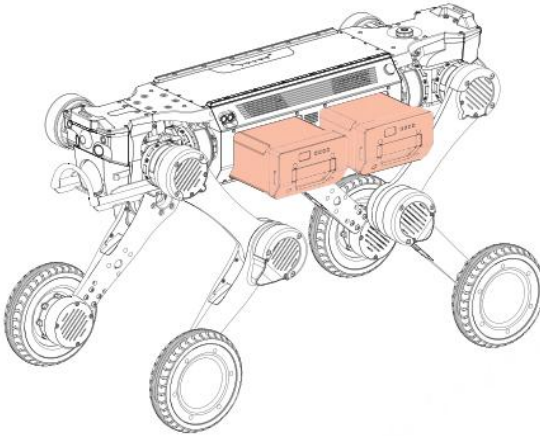

B. Power Off

Robot Dog Power Off: In the single-battery or dual-battery power supply mode, turn off any battery. The battery indicator will be turned off, the robot dog status indicator will be turned off and the robot dog will be powered off;

**Warning
Prompt**

- Whenever possible, please first adjust the robot dog to a horizontal prone posture once powered off; avoid powering off directly while the robot dog is in a standing posture.
- When the robot dog has only one powered-on battery, it is prohibited to shut down by directly pulling out the powered-on battery.

Emergency Stop and Protection

A. Hard Emergency Stop Trigger and Release

- **Hard Emergency Stop Trigger:** When the robot dog, whether in autonomous motion or remote control mode, is out of control or malfunctioning, the operator shall press down the red hard emergency stop button on the robot dog's back, in which case, the hard emergency stop red light will be normally on to trigger the hard emergency stop protection, and the robot dog will slowly lie down and remain motionless; a real-time pop-up alert will be displayed on APP.
- **Hard Emergency Stop Release:** if you turn the hard emergency stop button clockwise, the hard emergency stop will be released.

B. Soft Emergency Stop Trigger and Release

- **Soft Emergency Stop Trigger:** When the robot dog, whether in autonomous or remote-control mode, is out of control or malfunctioning, the operator can press down the soft emergency stop button on the remote control, then the robot dog will cease its current action and remain stationary in a standing posture; a real-time pop-up alert will be displayed on APP.
- **Soft Emergency Stop Release:** Once the robot dog and its surrounding environment are confirmed safe, please release the soft emergency stop via the APP, restoring both the APP and robot dog to normal status.

C. Overheat Protection

- The robot dog is equipped with comprehensive temperature detection functionality; once the joint, main control and battery of the robot dog is overheated, it will enter the state of overheat protection, ceasing all current motion, going prone and remaining still. The overheat location and temperature can be viewed on the APP; once the temperature has dropped to the normal level, you can continue to operate the robot dog.

D. Low Battery Protection

- When the charge level of both batteries is below 20%, the robot dog will enter the low battery warning state and charging should be performed immediately. When the charge level of both batteries is below 10%, the robot dog will trigger low battery protection so that it will automatically go prone and no longer respond to remote control commands from the handle. Please replace the batteries before continuing use.

E. Fall Protection

- The robot dog is designed to attempt recovery to the standing position after a fall, under the control of a reinforcement learning motion control model. When the surrounding environment does not permit recovery, the robot dog will maintain a fixed posture and give an alarm.

F. Expansion Bay Power Supply Protection

- The expansion bay is equipped with a separate power button, allowing independent control of its power on/off status. When the machine is powered on as a whole and the mounted payload has to be replaced, the expansion bay button can be triggered to directly power off all interfaces in the expansion bay without power outage of the machine as a whole. The expansion bay button should be inside the compartment to avoid accidental external contact causing the upper assembly to power down directly.

Payload Expansion

The space on the robot dog's back is flat, with a load of 30kg. It is equipped with dual rails on the back to facilitate the easy installation of mounted payload. The specific dimensions of dual rails are detailed as follows:

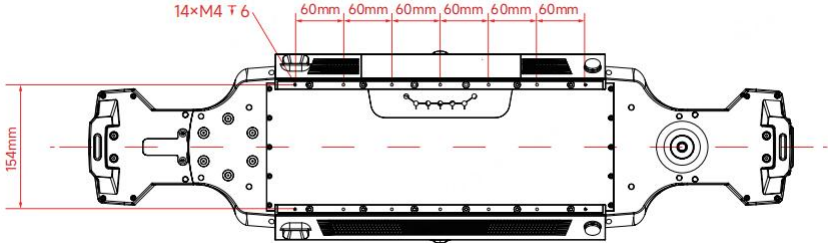

The back of robot dog has an expansion bay entrance. The power and communication cables of the mounted payload enter the expansion bay and connect to the aviation plug, enabling power supply and communication between the robot dog and the mounted payload;

Warning Prompt

- The robot, once fitted with a payload, shall only support the Basic Mode of Motion, so please Do Not use the Elevated Platform Mode after adding a payload.
- When adding a payload to the back of the robot, its motion performance may be affected, so please be sure to consult our after-sales service staff for related matters before installation.
- When using an external power interface to supply power to a load, please note that the total power the interface can provide externally does not exceed 480W.
- To ensure IP67 rating, all interfaces shall use IP67 aviation plugs with protective caps. Please cover any unused aviation plug interfaces with caps.
- When installing a top-mounted payload and connecting the power interface, be sure to have the robot dog powered off or have the expansion bay powered off.

Charging

Robot Dog Battery Charging

The dual batteries equipped on the robot dog both feature a plug-and-play quick change design, so for charging, you are only required to remove the batteries and charge them using the attached dual-battery charger cradle and charging adapter. The specific operations are detailed as follows:

A. Unplug the Battery

- Assume a horizontal prone posture, with the abdomen completely against the ground, legs naturally placed on both sides of the body, lower legs fully retracted, and all 4 knee joints and wheel-leg flat on the ground; lift the front/rear legs on the battery side in sequence to leave space for unplugging the battery;

- Alternatively, before turning off the robot dog, directly execute the battery swapping posture, in which case, the robot dog will automatically assume a horizontal prone posture and lift the front and rear legs on the battery side to leave space for unplugging the battery;
- Gently pull the battery hand strap to unlock the battery latch, then pull out the battery from the robot dog.

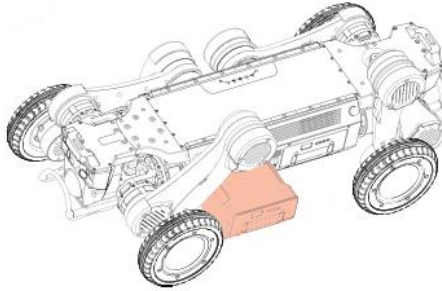

B. Charging Preparation

- Check the battery's exterior for integrity and confirm no bulging, leakage or other damage.
- Place the charger cradle on a hard and flat surface to ensure stable placement and prevent tipping in the process of charging.
- Connect the charger to a 220V AC power; turn on the charger cradle's rocker switch, on which the red light normally ON means that the charger cradle is connected and powered on.
- The charging environment should be kept dry and cool, away from anything flammable and explosive, with the ambient temperature around the charger cradle ranging from 0 to 50°C.

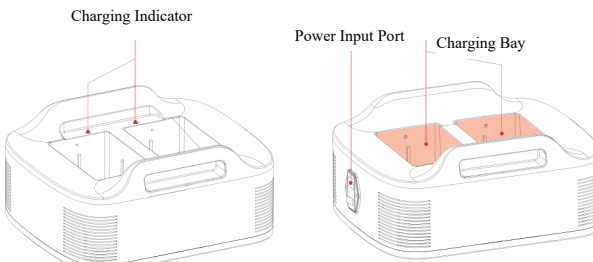

C. Battery Charging

- Align the battery with the charging interface on the charger cradle and insert it into the battery holder, which will support single-battery and dual-battery charging.

- Keep the indicator's green light on the charger cradle corresponding to the battery's charging status normally ON, indicating stable charging.
- The battery indicator will be illuminated in sequence to display the charging progress; and the LED normally ON denotes that its corresponding battery segment is fully charged, whereas a rapidly flashing LED denotes the segment presently under charging.
- When the battery is fully charged, all 4 indicator lights will remain normally ON, then please promptly disconnect the battery or the power source of charger cradle; the time for charging should not be longer than 6 hours.
- Once a fully charged battery is removed, please promptly turn off the charger cradle to avoid the charger cradle's plug being live, posing the risk of electric shock.

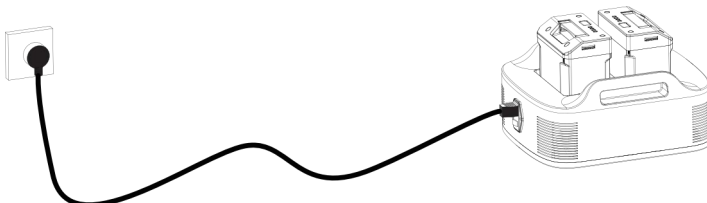

Note: It is prohibited to charge the battery using third-party chargers or charger cradles.

Remote Control Charging

When the battery indicator of remote control shows low level, please charge the remote control as shown in the figure below:

- Please charge the battery with the original USB charger.
- In the process of charging, the battery indicator of remote control will be illuminated in sequence to display the charging progress; and the LED normally ON denotes that its corresponding battery segment is fully charged, whereas a rapidly flashing LED denotes the segment presently under charging.
- To maintain the remote control battery in its optimal condition, please be sure to have it fully charged once a month.

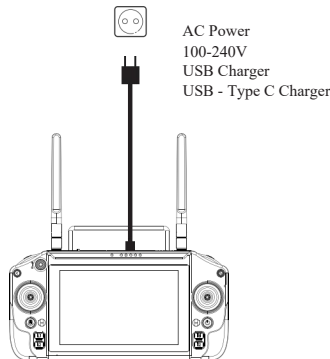

Transporting

2 modes of transporting are supported by the robot dog: transporting while powered off and transporting while powered on.

A. Transporting in Powered-Off State

- Place the robot dog in a horizontal prone posture, with its abdomen completely flush against the ground, legs naturally placed on either side of the body, lower legs fully retracted, and 4 knee joints and wheel-legs lying flat on the ground.
- In the process of transporting, 2 persons shall be caused to stand at the head and tail of the robot dog respectively, use both hands to hold the designated lifting points (the position of lower leg near the knee joint); lift the thigh and lower leg upward to the joint limit to prevent the dog's legs from swinging, enabling successful transporting of the dog.
- Once transported to the destination, place the robot dog on the ground, still in a horizontal prone posture.

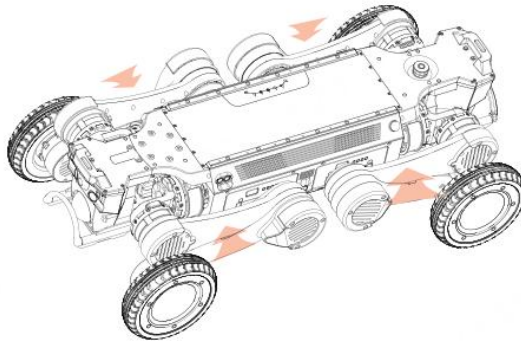

B. Transporting in Powered-On State

- The robot dog features a locked posture well developed. While powered on, its limbs can be locked, allowing a single worker to carry the robot dog by gripping the bumper with both hands.

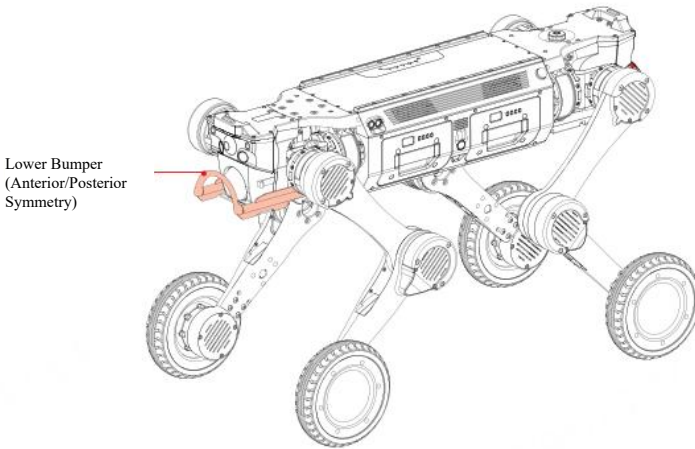

- Please pay close attention to the warning labels on the robot dog in the process of transport to avoid pinching hands with the dog's legs.
- When transporting the robot dog while it is powered on or immediately once powered off, grasp it at positions as far away from the joints and battery as possible to avoid burns from heat generated by the battery or joints.

Storage

A. Preparation before Storage

- **Environmental Preparation:** The storage environment shall be at the temperature of $-20^{\circ}\text{C}\sim 60^{\circ}\text{C}$, kept dry and ventilated, and kept away from strong magnetic fields (e.g., high-power transformers, electromagnets) and strong vibration sources (e.g., generators, crushers).
- **Cleaning:** Remove dust, stains and other impurities from the surfaces of the robot dog body, remote control, battery and charger cradle. Avoid liquids entering the robot dog's interfaces, radiator holes, etc., to prevent its internal components from being damaged by moisture.
- **Status Check:** Check the robot dog, remote control, battery, charger cradle, etc., to ensure no physical damage and keep them in a good functional state.
- **Battery Power Regulation:** Charge the battery to 50%~60%. This power range can effectively prevent battery damage due to excessive discharge, while also avoiding its capacity degradation caused by long-term storage at full charge.

B. Storage Method for Each Component

- **Storage of Robot Dog:** Power off a cleaned robot dog, pull out its batteries and place it stably inside the dedicated packing case.

- **Storage of Battery:** Place the two removed batteries in the packing case, each battery stored separately to avoid mutual compression or collision; and prevent the battery's positive and negative poles from contacting any metal object to avoid short circuiting.
- **Storage of Remote Control:** Power off the remote control, place it into the dedicated remote control protective sheath, and store both together in the packing case; avoid severe impact or compression to prevent the remote control shell from cracking, the buttons from being damaged or the display screen from breaking.
- **Storage of Charger:** Place the charger into the dedicated charger storage bag or the charger storage space inside the packing case; keep the charger isolated from other metal components to prevent wear or damage to the charger interface; check whether the charger plug is intact or not; if any damage or rust is found on the plug, replace it promptly before storage.
- **Storage of Packing Case:** Fold the packing case neatly and place it in a dry and ventilated environment; avoid moisture, mold or deformation from any heavy object pressing upon the case, which could affect its subsequent use. If the packing case is damaged or its load-bearing capacity is reduced, please promptly replace it with a new dedicated packing case to ensure safe storage and transportation of the equipment.

C. Maintenance and Inspection during Storage

a) Short-term storage (1~3 months)

- Conduct a monthly visual inspection on the robot dog, batteries, remote control and charger to confirm no damage, deformation, rust or other defects on all components.
- Check the charge level of batteries once; if below 40%, charge them to 50%~60% before continuing storage.
- Check whether the temperature and humidity of the storage environment are satisfactory or not, and promptly replace any desiccant that has become ineffective.

b) Long-term storage (over 3 months)

- Conduct a power-on test on the robot dog once every 2 months. Connect the robot dog to a power source (or install batteries), power it on and run it for 5~10min; check whether all functions of the robot dog are normal and whether any joint can move freely.
- Perform the charge-discharge maintenance on batteries once every month (discharge the battery to 30% and then recharge to 60%) to prevent memory effect and ensure battery capacity.
- Perform a functional check on the remote control and charger once every 3 months; test the sensitivity of remote control button and the charger's charging function for normal operation; if any abnormalities are found, promptly contact our after-sales service for repair.

D. Precautions for Storage

- Do Not store the robot dog or its accessories upside down or tilted, especially the robot dog itself, since upside-down storage may cause its internal components to shift or become damaged, thus affecting its normal operation.
- In the process of storage, Do Not place any heavy object on the equipment or its packing case to prevent deformation from deformation under pressure or component damage.
- If the equipment has to be taken out of storage for use, first place it in a room temperature environment to rest for 1~2 hours (if there is a significant temperature difference between the storage and usage environments). Wait until the device temperature matches the ambient temperature before performing the startup operation. This prevents internal condensation and damage to electronic components due to excessive temperature differences.
- Do Not let any non-professional disassemble the robot dog, battery, remote control or charger during storage; if equipment malfunctions or abnormalities are detected, promptly contact the manufacturer's after-sales service staff for professional inspection and repair to avoid any equipment damage or safety accident caused by self-disassembling.
- Detailed records related to storage (e.g., time for storage, time for inspection, maintenance status, etc.) must be properly registered to facilitate subsequent tracing of the equipment storage condition and timely identification and solution of potential problems.

Instructions for Remote Operations

Graphical Representation

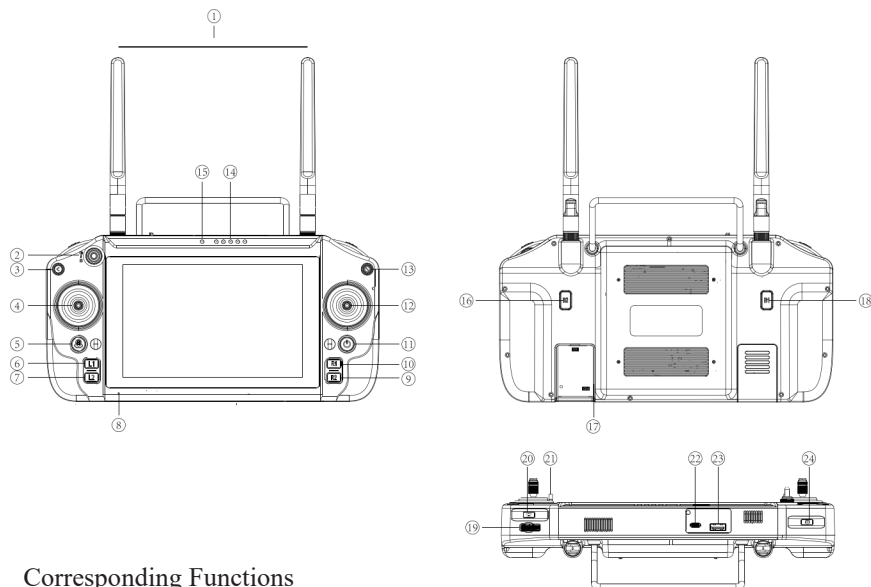

Corresponding Functions

SN	Button	SN	Button
①	2.4G/5.8G Antenna	⑬	Soft Emergency Stop
②	/	⑭	Remote Control Battery Level Indicator
③	Back	⑮	Pairing Indicator Light
④	Left Joystick	⑯	B2
⑤	H	⑰	SIM Card Slot
⑥	L1	⑱	B1
⑦	L2	⑲	Pulsator
⑧	Microphone	⑳	Fill Light
⑨	R2	㉑	Lanyard Hole
⑩	R1	㉒	Type-C Interface
⑪	Power On/Off	㉓	USB Interface
⑫	Right Joystick	㉔	Shooting/Video Recording

Details of Function Use

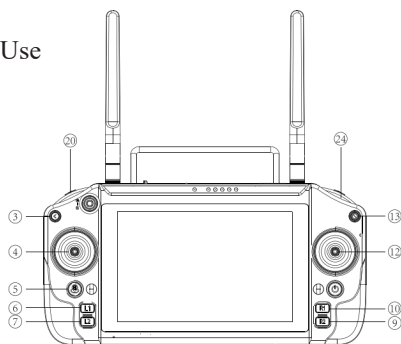

Button Function	Button operation	Function Definition
BACK to Previous	Click "BACK" (③)	BACK to Previous Page
Control the robot dog's forward, backward, leftward and rightward motion	Push "Left Joystick" (④)	The speed will gradually increase based on the joystick pressure and it shall be pulled to the very bottom corresponding to the upper limit set for each gear.
In-place Turning	Push "Right Joystick" (⑫)	Push the right joystick to control the robot dog's in-place turning
Turn all the way around while moving	Left Joystick + Right Joystick (④+⑫)	The left joystick is used to control movement and the right joystick is used to control direction.
Horizontal Turning Round	Stationary Mode + Right Joystick Leftward/Rightward Push (⑫)	In the stationary mode, push the right joystick leftward or rightward to perform the lean-left/lean-right action.
High/Low Posture	Stationary Mode + Right Joystick Upward/Downward Push (⑫)	In the stationary mode, push the right joystick upward or downward to perform the pitch-up/down action.
Lean-left/lean-right	H + Right Joystick Leftward/ Rightward Push (⑤+⑫)	Simultaneously push H and the right joystick leftward/rightward to perform a horizontal left/right turning action
Pitch Posture	H + Right Joystick Upward/ Downward Push (⑤+⑫)	Simultaneously push H and the right joystick upward or downward to perform the toggling action between high and low postures
Machine Forward/Rearward Switching	Simultaneously press: L1+R1 (⑥+⑩)	Machine Directional Angle Switching
Knee Joint Mode Switching	Simultaneously press: L2+R2 (⑦+⑨)	In-phase Knee Mode/Internal Opposing Knee Mode Switching
Soft Emergency Stop	Press the "Soft Emergency Stop" Button (⑬)	Machine Stop Motion
Photograph	Click the "Shoot" Key (⑲)	Photograph
Video Recording	Press and hold the "Shoot" Key (⑲) for 3 seconds	Press and hold for 3 seconds to record video; click again to cancel
Turn on/off the fill light	Click the "Fill Light" Key (⑳)	Each click will cycle through the following sequence: "Both Fill Lights ON - Front ON and Rear OFF - Rear ON and Front OFF - Both OFF".

Instructions of APP

Connect the Robot Dog to the Remote Control

- Keep the robot dog near the remote control before connection.
- Once the robot dog is powered on, press and hold the remote control's power button to start up.
- Click to open the "GenisDog" APP and wait for the remote control and robot dog to connect automatically.

Main Functions

Click "Enter Home Page"



Operate or configure the robot dog using the "GenisDog" APP

A. Main Page Function Display

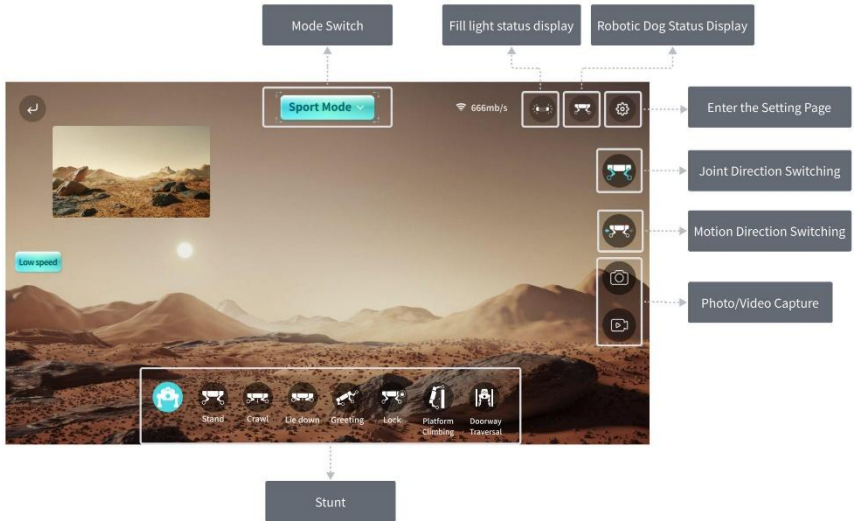

B. Mode Switch

Select the appropriate function mode based on your task scenario

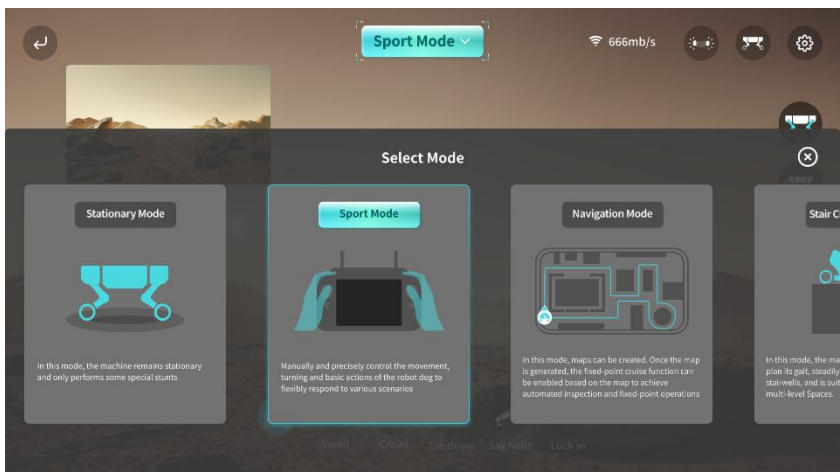

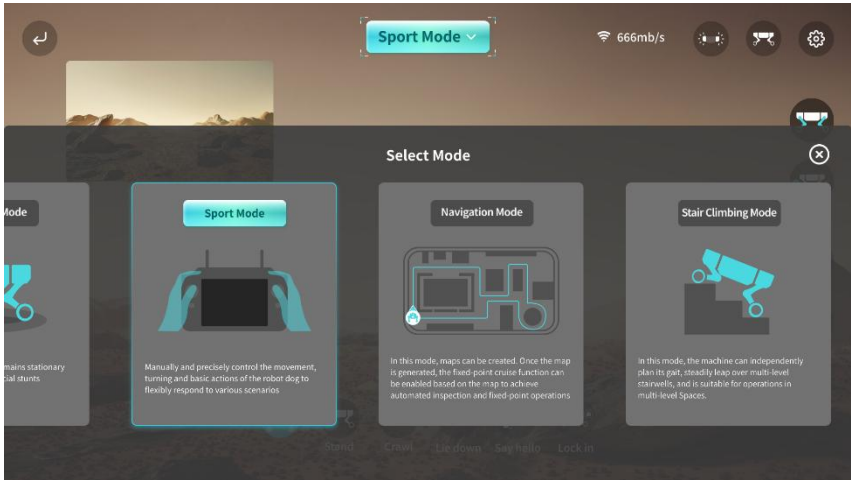

a) Stationary Mode

- **Function Description:** The robot dog will lock its function of mobility and maintain a stable standing posture in place.
- **Core Purpose:** Focused on performing stunt, precise calibration or equipment inspection.
- **Scenarios:** Power-on self-test, debugging and calibration, etc.

b) Sport Mode (Default)

- **Function Description:** Unlock all functions of mobility, allowing precise manual remote control of the robot dog's omnidirectional movement, turning and basic actions.
- **Core Purpose:** perform flexible and precise manual control in a complex environment.
- **Scenarios:** Complex terrain traversal, narrow space exploration, close observation of specific targets, etc.

c) Navigation Mode

- **Function Description:** In this mode, you can first guide the robot dog to build an environmental map. After the mapping is completed, you can set fixed point tasks based on this map to initiate automated cruising and operation.
- **Core Purpose:** Achieve autonomous and repeatable inspection and operational tasks, thereby liberating manpower.
- **Scenarios:** Automated inspection, preset route patrol, etc.

d) Stair Climbing Mode

- **Function Description:** In this mode, the robot autonomously plans its gait to steadily traverse multi-level stairs.
- **Core Purpose:** Efficient execution of cross-floor tasks.
- **Scenarios:** Multi-story building inspections.

C. Setting Interface

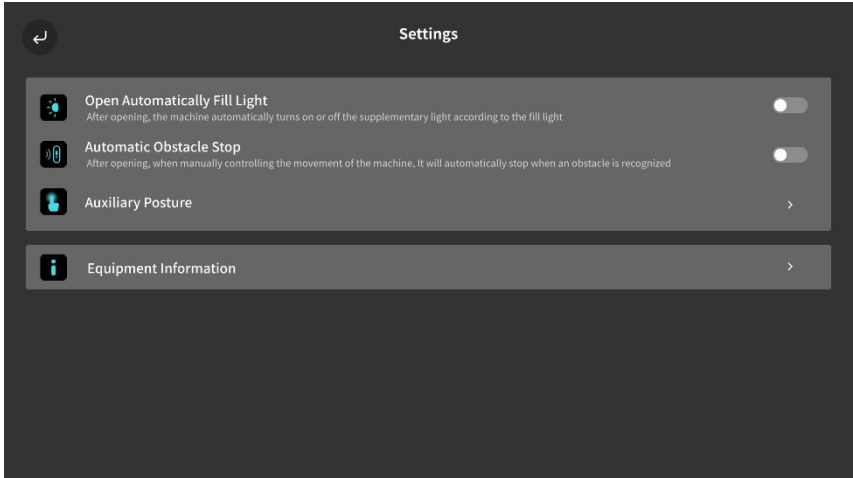

- a) **Auto Activation of Fill Light:** Automatically activate or deactivate the front fill light based on the ambient light intensity to ensure clear video capture in a dark light environment.
- b) **Automatic Obstacle Stop:** When enabled, the robot will automatically stop moving forward if an obstacle is detected during manual operation. This function is designed for collision avoidance during manual control in complex environments.
- c) **Auxiliary Posture:**
 - * **Battery Swapping Posture:** Triggered when battery replacement is required, the robot dog will assume a specific posture to facilitate battery insertion and removal;
- d) **Equipment Information:** View the robot dog's core information, including equipment serial number and software version of each subsystem (e.g., main control, motion, vision).

Software Continuous Upgrade Statement:

The ancillary APP of this product will undergo regular iterations and feature updates; therefore, descriptions in the manual may differ from the latest version. We are committed to continuously optimizing users' experience and specific functions are subject to what is actually presented within the APP.

Anomalies	Solutions
Power dead and startup failed	Gently press the battery switch to check battery level; Reinstall the battery: Keep batteries aligned with the machine body interface and install them properly until you hear a "click" sound; Clean Interfaces: Wipe the metal contact of the battery and the machine body with a dry cloth or eraser to remove oxidation.
What to do if the remote control connection is abnormal?	First, confirm whether the robot is powered on normally; if so, check whether the emergency stop status is deactivated, if not, shoot the trouble first, then deactivate the emergency stop after troubleshooting is completed; if the emergency stop is deactivated and the robot still cannot be controlled, restart the robot. If the abnormality persists, please contact after-sales service staff.
The robot's standing posture is abnormal upon power-on. Can it still be used?	Do Not control the robot's movement at this time, but immediately press down the soft emergency stop to make the robot go prone, then power off and restart, before attempting to make the robot stand again. If the abnormality persists, please contact after-sales service staff.
Blurry/No Signal in Image Transmission Screen	Gently wipe the camera surface with a lens cloth to remove dust and stains; optimize the signal environment by avoiding strong interference sources like Wi-Fi and Bluetooth, and shorten the distance between the control terminal and the robot dog to be $\leq 10\text{m}$; Turn off the robot and the control terminal, then restart and test the image transmission. If there is still no signal after restarting, please contact after-sales service.
What terrains can the robot adapt to?	The robot is suitable for relatively flat terrain like plains and grasslands, and can navigate complex terrains such as stairs and slopes. However, please avoid operating and using the robot on extreme terrains (e.g., overly smooth surfaces like ice, sharp or highly uneven terrain, edges at heights, etc.).
What to do when encountering unsolvable problems even after consulting this manual?	Save data and promptly contact after-sales service.

A. Routine Cleaning Guidelines

After using the machine, if there are stains on the surface, please clean them promptly; before wiping the body, first turn off the power, then use a dry, clean and soft cloth to wipe, pay special attention to whether the camera and radar are cleaned thoroughly and avoid scratching lens with any hard object.

Do Not use corrosive liquids such as alcohol or disinfectants for cleaning.

B. Regular Inspection and Maintenance

To ensure the robot dog's operational stability and extend its lifespan, regular preventive inspection and targeted maintenance are required.

Maintenance Cycle	Maintenance Module	Specific Maintenance
Daily Check (Approx. 5min before each use)	Appearance and Structure	Check the body and leg links for any deformation or crack; Check whether joint and foot fastening screws are loose or not; Check the foot tires for detachment or severe wear (tread worn smooth); if present, please replace them promptly.
	Battery and Power Supply	Check whether the battery shell has exhibited no bulging or leakage; Have the battery securely installed to prevent loosening in the process of operation; Check the battery level via the screen/app (charge if below 20%)
	Functional Test	Start the equipment and operate the joystick to test whether all joints can move freely and whether there is any stuttering or abnormal "Click" sound; Check and make sure that the camera and sensor lenses are unobstructed and that the image transmission screen is clear; Test whether the remote control signal is stable within 10m (no delay).
Weekly Maintenance (Once a week, approx. 20min)	Overall Machine Maintenance	Wipe the body shell with a dry and soft cloth (for oily stains, lightly dampen with a small amount of clean water and then wipe gently); Gently wipe dust off the camera and LiDAR surfaces with a lens cloth; Use a brush to clean debris from gaps around sensors; Use tweezers to clean weeds or threads entangled in the tires to prevent jamming.
	Joints and Drive System	Wipe all joint surfaces and crevices with a dry and soft cloth to remove mud and dust; after wading, dry the bearing part using a hairdryer in low-temperature gear; Manually articulate each joint to confirm no jamming, abnormal noise, loose screws or tangled/worn cables.
	Battery Maintenance	Fully charge the battery before use (avoid storing it at below 80% charge for extended periods); perform one full charge-discharge cycle every 3 weeks (fully charge it, then use it until below 20% before recharging).

DESCRIPTION OF PRODUCT Daily Maintenance

Monthly Maintenance (Once a month, approx. 30min)	Software Update	Check the firmware update via the ancillary APP or official website; Download and install the update as prompted (keep the battery level \geq 50% during upgrade; Do Not cut power).
	Component Status Assessment	Check joint connectors (e.g., robotic arm shafts, leg bearings) monthly; if loose, tighten with a specialized wrench. Component Status Assessment: Check tire wear monthly; if damaged, replace promptly; check battery health every 3 months (view cycle count via the device's APP; replacement is recommended if it exceeds 500 cycles).



Precautions

- Power off the equipment during maintenance to avoid damage from accidental operation.
- When replacing spare parts (e.g., tires, batteries), please use genuine parts; non-genuine parts may compromise the equipment safety.
- In case of any complex malfunction (e.g., joint jamming, sensor malfunction), please Do Not disassemble it yourself, but contact after sales technical support.

A. The warranty periods for main components of the product you purchased are as shown in the following table:

Component Name	Warranty Period
Overall Unit	1 year
Mainboard	12 months
Joint Module	7 months
Battery	6 months/200 cycles

Note: Vulnerable parts such as the outer shell, foot tires and accessories like the transport case are not covered under the warranty. Please consult after-sales support if needed. Different warranty periods are offered for different components of the Product and mileage limits for them are set. If either the mileage of the Product or the warranty period for specific components exceeded the limit stated in the table above, the warranty would be automatically converted to paid repair service.

After you purchase this product, the warranty period shall be commenced from the date you sign for its receipt. To protect your interest, please be sure to check and confirm on the spot that the product and its attached articles/data are in good or normal condition upon signing for the receipt, otherwise, please contact Party B immediately. According to the logistics company's requirement for claim settlement, for any damage caused by logistics transportation, you shall contact the after-sales department within 24 hours of discovering the logistics-related damage; otherwise, your request cannot be processed.

B. Exceptions to Free After-Sales Service: Under any of the following circumstances, the entitlement of free after sales service for your product under warranty will be void. However, you may still opt for paid repair services if available.

- Damage from collisions, drops, burns, etc., not caused by the product's own quality defects (e.g., human factors)
- Any acts of secondary development of the product (with or without prior authorization), hardware modification, disassembly, etc.;
- Damage caused by unauthorized repairs of components, circuit modifications, battery pack alterations or improper use of chargers;
- Damage caused by immersion in liquid, debris ingress, chemical contact, scratches, etc.
- Damage caused by any use beyond the safe load limit of the product;
- Damage caused by prolonged inactivity of the product;
- Damage caused by failure to activate, install or use the product as required by the user manual;
- Product malfunction or damage caused by the use of non-genuine accessories (including but not limited to replacement, retrofitting, etc.);
- Damage caused by operational errors/intentional actions leading to the product impact against any hard objects, drops or evident signs of impact, collision or scratches on the product surface;

- Damage caused by force majeure or extreme adverse conditions (including but not limited to strong magnetism/strong interference/high temperature/low temperature/ natural disasters);
- Damage caused by operation in environments with sharp terrain, significant undulations, smooth surfaces, etc.

C. How to Send for Repair;

- When contacting for after-sales service, please describe all defects of the product in detail. We will first attempt to diagnose and solve your problems via phone, email or remote assistance.
- If the above methods are unavailable to solve your problems, you may send the product to Party B for further test, upon which corresponding arrangements or decisions will be made. If, upon inspection, it does not comply with the free warranty policy, you may choose paid after-sales service (Party B will then confirm the relevant after-sales services and charges with you) or have the original machine returned.
- ※ You are responsible for advance payment of the mailing fees when sending the product to Party B.
- ※ Party B, upon receipt of the returned product, will conduct fault detection to determine liability for problems found. If it is confirmed through test to be the product's own quality defect and fall within the warranty period, then all related costs and courier fees for return will be borne by Party B.
- ※ If the product, upon inspection, is not eligible for free repair, you may opt for paid repair or have the faulty product returned. Party B will confirm the repair program with you, if accepted, Party A will pay all fees and expenses according to the confirmed program; if not accepted, the equipment will be returned to Party A, and all related inspection fees, labor costs or freights arising therefrom will be borne by Party A.
- ※ Water ingress to the main body of the product, charger or remote control, if occurred, will severely affect the product performance, as a result, the product will become irreparable. Therefore, Party B cannot provide repair services but may offer paid replacement services, as the case may be. Please be informed that and consider returning as appropriate.

“
**成为智能机器人
全球领军企业
开创通用机器人生态**
”
To Become a Global Leader
in Intelligent Robots
and Create a General Purpose Robot
Ecosystem



YouTube Official Account



Official Website

智元D1售后服务指南

AGIBOT D1 After-Sales Service Guide

报修方式/Methods for Reporting Repairs

我们提供7x12小时（国家法定节假日除外）服务,并承诺在收到请求后30分钟内首次响应,您可通过以下任一渠道联系我们:

- 服务热线: 400-186-0818
- 微信公众号: 智元AGIBOT→点击“在线咨询”→选择“售后咨询”
- 服务邮箱: AfterSalesService@agibot.com

We provide 7x12-hour service (excluding national statutory holidays) and guarantee an initial response within 30 minutes of receiving your request. You may contact us through any of the following channels:

- Service Hotline: 400-186-0818
- WeChat Official Account: Zhiyuan AGIBOT → Click “Online Consultation” → Select “After-Sales Support” Service
- Email: AfterSalesService@agibot.com

企业微信售后

Wechat After-sales Support

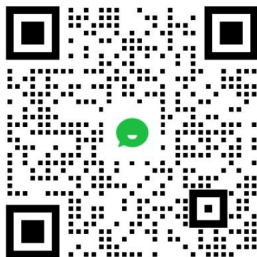

智元创新(上海)科技股份有限公司
咨询热线: 400-186-0818
官网: zhiyuan-robot.com